

3 Phase Voltage Monitor WVM Series Motor Protector



ANSI Device #27/47/59

- Protects Against: Phase Loss & Reversal; Over, Under & Unbalanced Voltages; Short Cycling
- 10 Fault Memory & Status Displayed on 6 LED Readout
- Switch Selectable Automatic Restart, Delayed Automatic Restart, & Manual Reset
- Isolated 10 A SPDT Relay Contacts
- ASME A17.1 rule 210.6
- NEMA MG1 14:30, 14:35
- IEEE C62.41-1991 Level B

Approvals:

Connection

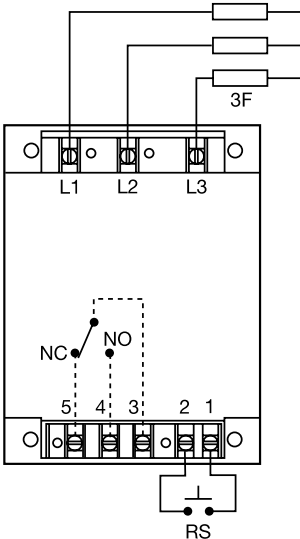

CAUTION:

2 amp max fast acting fuses must be installed externally in series with each input. (3)
Relay contacts are isolated. Dashed lines are internal connections.

F = Fuses
NO = Normally Open
NC = Normally Closed
RS = Optional Remote Reset Switch

Description

The WVM Series provides protection against premature equipment (motor) failure caused by voltage faults on the 3 Phase Line. The WVM's microcontroller design provides reliable protection even if regenerated voltages are present. It combines dependable fault sensing with a 10 fault memory and a 6 LED status display. Part instrument, part control, the WVM protects your equipment when you're not there and displays what happened when you return. The WVM is fully adjustable and includes time delays to prevent nuisance tripping and improve system operation. Time delays include a 0.25 to 30 s adjustable trip delay, an adjustable 0.25 to 64 m (in 3 ranges) restart delay, plus a unique 3 to 15 s true random start delay. The random start delay prevents voltage sags caused by simultaneous restarting of numerous motor loads after a power outage.

Operation

The output relay is energized when all conditions are acceptable and the WVM is reset. A restart and/or random start delay may occur before the output relay is energized.

Field Adjustment: Select the line voltage listed on the motor's name plate. This automatically sets the over and under voltage trip points. Consult the equipment's manufacturer specifications for the correct trip delay, unbalance percentage, and restart/reset operation and restart delay. Make connection to all three line phases as shown in the connection diagram. Apply power. If the relay fails to energize, view the LEDs for the cause, and correct the problem. If the phase sequence is incorrect, swap any two wires. No further adjustment should be required to achieve maximum equipment protection.

Read Memory: Fault(s) stored in the memory are indicated when the yellow LED is flashing. To read memory, rotate selector from Manual to Read Memory. The last fault will be displayed. Repeat this operation to read the second to the last fault. Repeat until up to 10 faults are noted.

Memory Reset: To clear the memory of all faults stored, rotate selector to Clear Memory for 5 seconds. The yellow LED will turn off.

Memory Overload: The 11th fault causes the first to be removed from memory. Only the 10 most recent faults are retained.

Random Start Delay: A new 3 to 15 s random start delay is selected by the microcontroller when a fault is corrected and when the operating voltage (L1, L2, L3) is applied to the WVM. A random start delay does not occur when the reset is manual.

Automatic Restart: Upon fault correction, the output will re-energize after a random start delay.

Automatic Restart Upon Fault Trip: When a fault is sensed for the full trip delay, the output de-energizes and a restart delay is initiated. This delay locks out the output for the delay period. Should the fault be corrected by the end of the restart delay, the output will re-energize after a random start delay. A restart delay will also occur when operating voltage (L1, L2, L3) is applied to the WVM.

Manual Reset: After a fault condition is corrected, the WVM can be manually reset. There are two methods; a customer supplied remote switch, or the onboard selector switch.

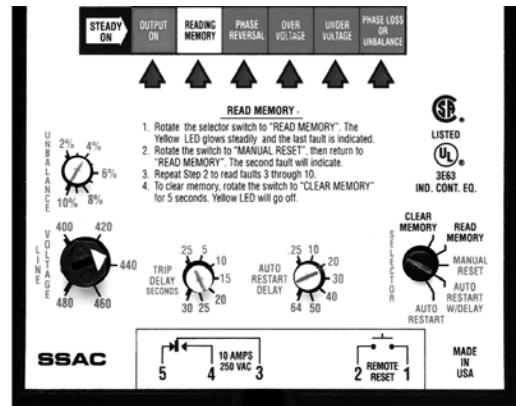

Manual Reset (Onboard): Rotate selector switch from the Manual Reset position to Auto Restart w/ Delay then back again to Manual Reset within 3 seconds. The output will immediately energize.

Remote Reset: Reset (Restart) is accomplished by a momentary contact closure across terminals 1 & 2. The output will immediately energize. Remote switch requirements are ≥ 10 mA at 20 V DC and the reset terminals are not isolated from line voltage. A resistance of ≤ 20 K Ω across terminals 1 & 2 will cause immediate automatic restart.

Automatic Restart Upon Fault Correction: (P/N includes an R)

When a fault is sensed for the full trip delay, the output relay de-energizes. Upon correction of the fault, a restart delay begins. At the end of this delay, the output will re-energize after a random start delay. If a fault occurs during restart timing, the restart time delay will be reset to zero, and the output will not energize until the restart delay is completed.

-60 Option: Add the suffix -60 to any automatic restart part number to remove the Random Start Delay feature. See example P/N's below.

WVM Series

X 3 Phase Line Voltage -6 - 200 ... 240 V AC -8 - 355 ... 425 V AC -9 - 400 ... 480 V AC -0 - 500 ... 600 V AC	X Unbalance -1 - 2 ... 10%	X Trip Delay -1 - 0.25 ... 30 s	X Reset Method -A - Switch Selectable: Automatic Restart Upon Fault Trip -R - Switch Selectable: Automatic Restart Upon Fault Correction	X Restart Delay -L - 0.25 ... 64 s -N - 6 ... 300 s -H - 0.25 ... 64 m
---	--	---	---	--

Example P/Ns: **WVM011AL,**
WVM911AL-60 (No Random Restart Delay)

3 Phase Voltage Monitor WVM Series Motor Protector

Voltage
Monitors

Technical Data

Line Voltage	3 phase Delta or Wye with no connection to neutral	
Type	Adjustment Range	
Operating Voltage	200 ... 240 V AC	
	355 ... 425 V AC	
	400 ... 480 V AC	
	500 ... 600 V AC	
Frequency	50 ... 60 Hz	
Overvoltage, Undervoltage, & Voltage Unbalance		
Overvoltage Trip Point	109 ... 113% of adjusted voltage	
Reset Voltage	-2% of trip point	
Undervoltage Trip Point	88 ... 92% of adjusted voltage	
Reset Voltage	+2% of trip point	
Voltage Unbalance	Adjustable from 2 ... 10%	
Trip Delay	Adjustable from 0.25 ... 30 s +/-15%	
Phase Loss	≥ 15% unbalance	
Response Time	≤ 200 ms	
Random Start Delay Range	3 ... 15 s	
Reset (Restart) Delay		
Low Range	0.25 ... 64 s +/-15%	
Normal Range	6 ... 300 s +/-15%	
High Range	0.25 ... 64 m +/-15%	
Fault Memory		
Type	Nonvolatile RAM	
Capacity	Stores last 10 faults	
Status Indicators	6 LEDs provide existing status & memory readout	
Note: 50% of operating line voltage must be applied to L1 & L2 for operation of status indicators		
Output		
Type	Electromechanical relay	
Form	Isolated single pole double throw (SPDT)	
Rating	10 A resistive @ 250 V AC; 6 A inductive (0.4 PF) at 250 V AC	
Protection		
Surge	IEEE 62.41-1991 Level B	
Isolation Voltage	≥ 2500 V RMS input to output	
Mechanical		
Mounting	Surface with 2 or 4 #8 (M4 x 0.7) screws	
Termination	Screw terminals with captive wire clamps for up to #12 AWG (3.2 mm ²) wire	
Environmental		
Operating/Storage Temperature	-40°C ... +65°C / -40°C ... +85°C	
Weight	≅ 25 oz (709 g)	

Reset on Balance	
Selected Unbalance %	Reset %
2	1.8
3	2.7
4	3.6
5	4.5
6	5.4
7	6.3
8	7.2
9	8.1
10	9

7

Accessories

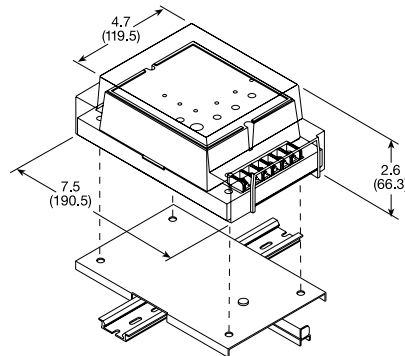
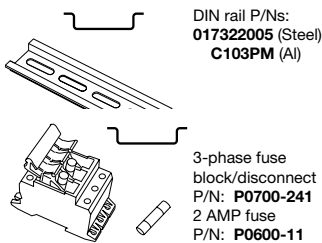

Mechanical View

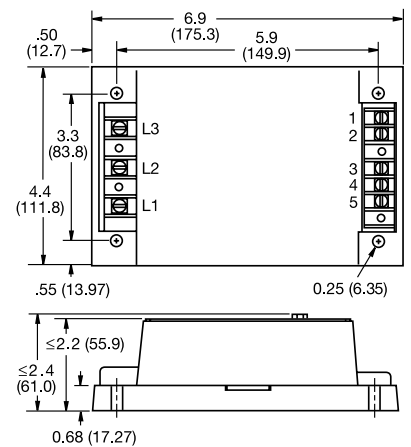

P/N: P1011-38

35mm DIN Rail Adaptor

The P1011-38 provides an easy method of mounting the WVM Series on 35mm DIN rail. The P1011-38 adaptor includes four mounting screws. 7 x 4.5 x .33 in. (177.8 x 114.3 x 8.4 mm)

P/N: P0500-153

Inches (Millimeters)

Clear Tamperproof Cover

The P0500-153 protects against unauthorized adjustment of the trip points. It prevents the resetting of manual units by the equipment's operator. It isolates line-level connection points preventing contact during troubleshooting operations. Alignment dimples allow drilling (5 places) for limited access to adjustment knobs and the reset switch. Included are (2) spacers, (5) hole plugs. 7.5 x 4.7 x 2.6 in. (190.5 x 119.4 x 66 mm)

Inches (Millimeters)

WVM02B01 09-15-04