

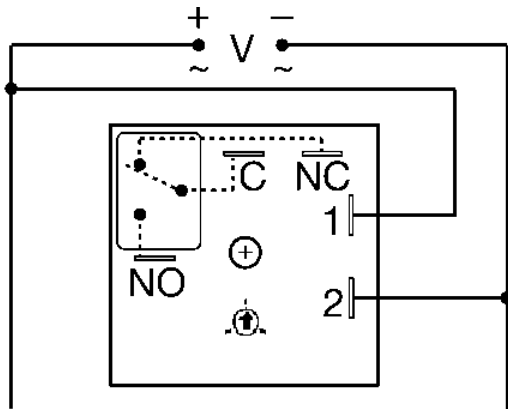

**SSAC Product Line Conversion Notification September 15, 2005**  
**KRDM Series Part Numbers**

**Important Differences Between Product Designs**

Specification	Pre 2005 Design	2005 Generation II Design
<b>Time Delay</b>		
Recycle Time	≤ 250 ms	≤ 150 ms
Range	0.2 s ... 100 m in 5 adjustable ranges or fixed	0.1 s ... 100 m in 5 adjustable ranges or fixed
Tolerance (Factory Calibration)	+/-10%	≤ +/- 5%
<b>Input</b>		
Power Consumption	12, 24 VDC ≤ 0.65W; 24 VAC: ≤ 1 VA; 110 VDC : ≤ 2W; 120 VAC ≤ 2 VA	AC ≤ 2 VA; DC ≤ 2 W
<b>Output</b>		
Contact Ratings (@ 40°C)	10A resistive @ 125 VAC 5A resistive @ 30 VDC; ¼ HP @ 125 VAC Max. Switching voltage: 230 VAC (5A resistive)	10A resistive @ 125 VAC 5A resistive 28 VDC; ¼ HP @ 125 VAC
<b>Mechanical</b>		
Terminals		Terminal layout is different. Onboard adjust requires an adjustment tool.



Pre 2005 Design

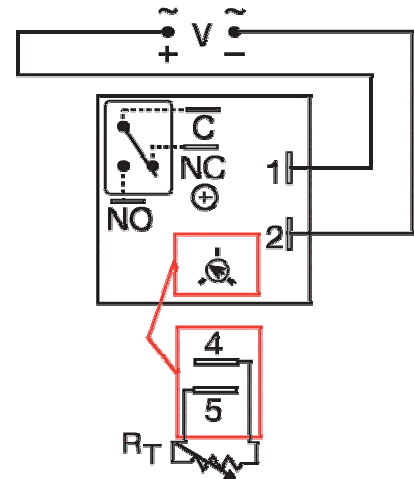

2005 Generation II Design

**Legend:**

- V = Input voltage
- C = Common, Transfer Contact
- NO = Normally Open
- NC = Normally Closed
- Dashed lines are internal connections