

Delay On Break (Release)

TSDB Series

Timing Module



- Fixed or Adjustable Delays
0.1 s ... 1000 m in 6 Ranges
- +/-0.5% Repeat Accuracy
- +/- 1% Factory Calibration
- 12 VDC...230 VAC in 5 Ranges
- 1 A Solid State Output
- Encapsulated

Approvals:

Accessories

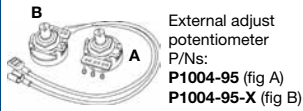

External adjust potentiometer
P/Ns:
P1004-95 (fig A)
P1004-95-X (fig B)



Mounting bracket
P/N: P1023-6



Female quick connect
P/N:
P1015-64 (AWG 14/16)



Quick connect to screw adaptor
P/N: P1015-18



Versa-knob
P/N: P0700-7

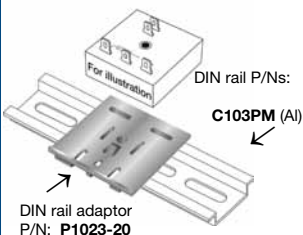

DIN rail P/Ns:

C103PM (Al)

DIN rail adaptor
P/N: P1023-20

See accessory pages for specifications.

Description

The TSD Series is designed for more demanding commercial and industrial applications where small size, and accurate performance is required. The factory calibration for fixed time delays is within 1% of the target time delay. The repeat accuracy, under stable conditions, is 0.5% of the time delay. The TSD Series is rated to operate over an extended temperature range. Time delays of 0.1 seconds to 1000 minutes are available. The output is rated 1 A steady and 10 A inrush. The modules are totally solid state and encapsulated to protect the electronic circuitry.

Operation

Input voltage must be applied before and during timing. Upon closure of the initiate switch, the output energizes. The time delay begins when the initiate switch is opened. The output remains energized during timing. At the end of the time delay, the output de-energizes. The output will energize if the initiate switch is closed when input voltage is applied.

Reset: Reclosing the initiate switch during timing resets the time delay. Loss of input voltage resets the time delay and output.

Function

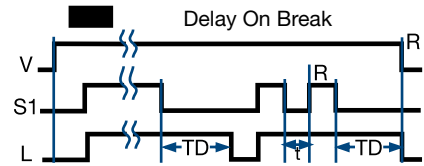

V = Voltage L = Load S1 = Initiate Switch
TD = Time Delay R = Reset
t = Incomplete Time Delay — = Undefined time

Connection

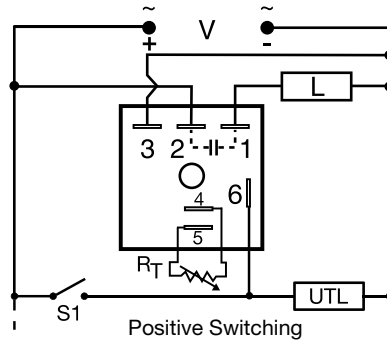

Positive Switching

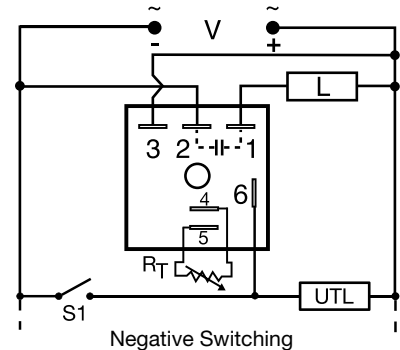

Negative Switching

R_T is used when external adjustment is ordered.
Dashed lines are internal connections.

UTL = Optional Untimed Load L = Timed Load S1 = Initiate Switch

Available Models-

TSDB120P
TSDB323P
TSDB421

TSDB2160S
TSDB4145S
TSDB425

TSDB320P
TSDB420
TSDB431

Don't see what you need? Call us for a minimum quantity and price quote!

Ordering Table

TSDB Series	X Input	X Adjustment	X Time Delay*	X Switching Mode (V DC Only)
	-1 - 12 V DC	-1 - Fixed	-0 - 0.1 ... 10 s	-P - Positive
	-2 - 24 V AC	-2 - External Adjust	-1 - 1 ... 100 s	-N - Negative
	-3 - 24 V DC	-3 - Onboard Adjust	-2 - 10 ... 1000 s	
	-4 - 120 V AC		-3 - 0.1 ... 10 m	
	-6 - 230 V AC		-4 - 1 ... 100 m	
			-5 - 10 ... 1000 m	

Example P/N: **TSDB420** Fixed – **TSDB110.1SP**

* If Fixed Delay is selected, insert delay [0.1 ... 1000] followed by (S) sec. or (M) min.

Delay On Break (Release)

TSDB Series

Timing Module

Dedicated
timers

5

Technical Data

Time Delay Range Repeat Accuracy Tolerance (Factory Calibration) Reset Time Initiate Time Time Delay vs. Temperature & Voltage	0.1 s ... 1000 m in 6 adjustable ranges or fixed +/-0.5 % or 20 ms, whichever is greater ≤ +/-1% ≤ 150 ms ≤ 20 ms ≤ +/-2%
Input Voltage Tolerance Power Consumption Line Frequency DC Ripple	12 or 24 V DC; 24, 120, or 230 V AC +/-15% AC ≤ 2 VA; DC ≤ 1 W 50 ... 60 Hz ≤ 10 %
Output Type Form Maximum Load Current Off State Leakage Current Voltage Drop DC Operation	Solid state Normally Open, closed before & during timing 1 A steady state, 10 A inrush at 60°C ≅ 5 mA at 230 V AC; DC ≅ 1 mA AC ≅ 2.5 V at 1 A; DC ≅ 1 V at 1 A Positive or negative switching
Protection Circuitry Dielectric Breakdown Insulation Resistance Polarity	Encapsulated ≥ 2000 V RMS terminals to mounting surface ≥ 100 MΩ DC units are reverse polarity protected
Mechanical Mounting Termination	Surface mount with one #10 (M5 x 0.8) screw 0.25 in. (6.35 mm) male quick connect terminals
Environmental Operating/Storage Temperature Humidity Weight	-40°C ... +75°C / -40°C ... +85°C 95% relative, non-condensing ≅ 2.4 oz (68 g)

External Resistance vs Time Delay

In Secs. or Mins.

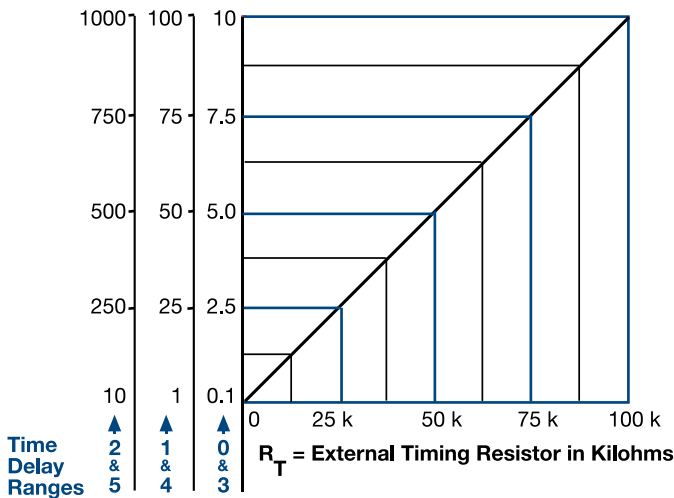

This chart applies to externally adjustable part numbers.
 The time delay is adjustable over the time delay range selected by varying the resistance across the R_T terminals; as the resistance increases the time delay increases.
 When selecting an external R_T , add the tolerances of the timer and the R_T for the full time range adjustment.
Examples: 1 to 50 S adjustable time delay, select time delay range 1 and a 50 K ohm R_T . For 1 to 100 S use a 100 K ohm R_T .

Mechanical View

Fixed and External Adjust

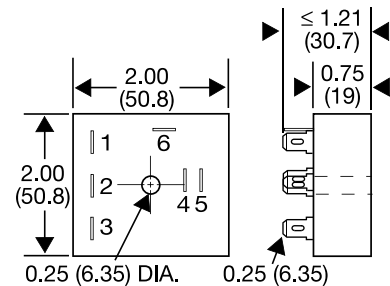

Onboard Adjust

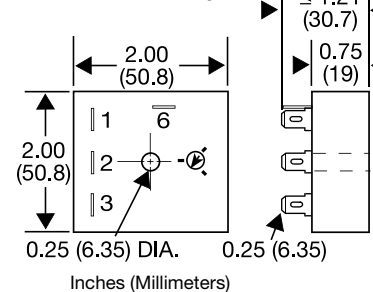

TSDBGen 09:10