

# Single Shot (Pulse Former) THS Series Timing Module



**Discontinued Design**  
For more information contact  
Technical Service at  
**(888)385-1221**

- Momentary or Maintained Initiation
- +/-2% Repeat Accuracy
- Fixed or Adjustable Delays From 0.1 ... 600 s

### Description

The THS Series may be used to directly control lamp or heater loads of up to 4,600 W. Applications such as exposure timing and heat sealing timing are made simple with increased life only possible with solid state.

### Operation

Input voltage must be applied to the input before and during timing. Upon momentary or maintained closure of the initiate switch (leading edge triggered), the output is energized for a measured interval of time. At the end of the delay, the output de-energizes. Opening or reclosing the initiate switch during timing has no effect on the time delay. The output will energize if the initiate switch is closed when input voltage is applied.

**Reset:** Reset occurs when the time delay is complete and the initiate switch is opened. Loss of input voltage resets the time delay and output.

Approvals:

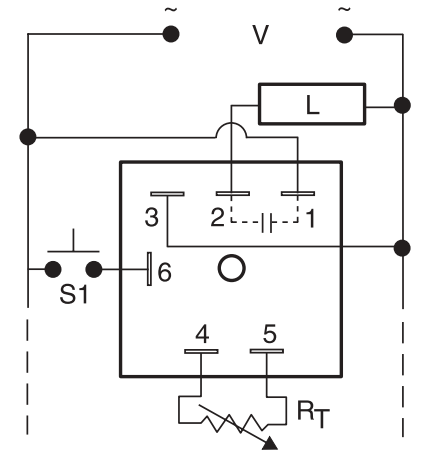

R<sub>T</sub> is used when external adjustment is ordered.

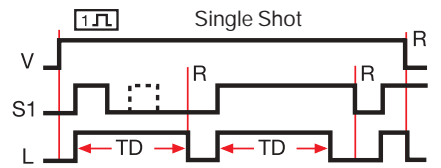

V = Voltage L = Load S1 = Initiate Switch  
TD = Time Delay R = Reset

### Ordering Table

THS Series	X Input	X Adjustment	X Time Delay *	X Output Rating
	-2 - 24 V AC	-1 - Fixed	-1 - 0.1 ... 3 s	-A - 6 A
	-4 - 120 V AC	-2 - External Adjust	-2 - 0.5 ... 60 s	-B - 10 A
	-6 - 230 V AC		-3 - 2 ... 180 s	-C - 20 A
			-4 - 5 ... 600 s	

Example P/N: **THS421B** Fixed - **THS410.5C**

\*If Fixed Delay is selected, insert delay [0.1...600] in seconds.

### Technical Data

<b>Time Delay</b>	
Type	Analog circuitry
Range	0.1 ... 600 s in 4 adjustable ranges or fixed
Repeat Accuracy	+/-2%
Tolerance (Factory Calibration)	≤ +/-10%
Recycle Time	100 ms
Time Delay vs. Temperature & Voltage	≤ +/-10%
<b>Input</b>	
Voltage	24, 120, or 230 V AC
Tolerance	+/-15%
Line Frequency	50 ... 60 Hz
<b>Output</b>	
Type	Solid state
Form	Normally Open, closed during timing
Rating	Output Steady State Inrush**
	A 6 A 60 A
	B 10 A 100 A
	C 20 A 200 A
Minimum Load Current	100 mA
Voltage Drop	≅ 2.5 V at rated current
<b>Protection</b>	
Circuitry	Encapsulated
Dielectric Breakdown	≥2000 V RMS terminals to mounting surface
Insulation Resistance	≥100 MΩ
<b>Mechanical</b>	
Mounting **	Surface mount with one #10 (M5 x 0.8) screw
Package	2 x 2 x 1.51 in. (50.8 x 50.8 x 38.4 mm)
Termination	0.25 in. (6.35 mm) male quick connect terminals
<b>Environmental</b>	
Operating Temperature	-20°C ... +60°C
Storage Temperature	-40°C ... +85°C
Humidity	95% relative, non-condensing
Weight	≅ 3.9 oz (111 g)

Desired Time Delay*				R <sub>T</sub> Megohm
Seconds				
1	2	3	4	
0.1	0.5	2	5	0.0
0.5	10	30	60	0.5
1.0	20	60	120	1.0
1.5	30	90	180	1.5
2.0	40	120	240	2.0
2.5	50	150	300	2.5
3.0	60	180	360	3.0
			420	3.5
			480	4.0
			540	4.5
			600	5.0

\* When selecting an external R<sub>T</sub> add at least 20% for tolerance of unit and the R<sub>T</sub>.

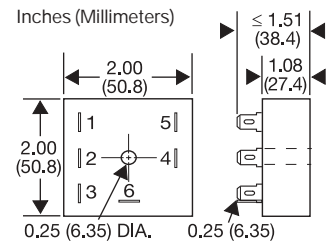

### Accessories

Female quick connect  
P/N: P1015-64 (AWG14/16)

External adjust potentiometer  
P/N: P1004-XX

Quick connect to screw adaptor  
P/N: P1015-18

Plug-on adjustment module  
P/N: VTP(X)X

Versa-knob  
P/N: P0700-7

See accessory pages at the end of this section.

\*\*Must be bolted to a metal surface using the included heat sink compound. The maximum mounting surface temperature is 90°C. Inrush: Non-repetitive for 16 ms.

Time Delay	VTP P/N	Fig. A P/N	Fig. B P/N
1 - 0.1 ... 3 s	VTP4B	P1004-12	P1004-12-X
2 - 0.5 ... 60 s	VTP4F	P1004-12	P1004-12-X
3 - 2 ... 180 s	VTP4J	P1004-12	P1004-12-X
4 - 5 ... 600 s	VTP5N	P1004-13	P1004-13-X