

Interval (Single Pulse On Operate) TH2 Series Power Timing Module



TEN YEAR WARRANTY

- High Load Capacity: 20 A, 200 A Inrush
- Zero Voltage Switching (ZVS), Long Load Life
- Total Harmonic Distortion (THD) < 5%, No Harmonic or Wearing Which Results in High Efficiency
- Fixed or Adjustable Time Delays From 0.1 ... 600 s
- Repeat Accuracy: $\pm 2\%$

Obsolete Specification
Redesigned product is available
see new specifications at:
www.ssac.com/standard/standard.htm

Description

The TH2 is the combination of a timer and a solid state relay into one easy-to-use solid state molded module. When mounted to a metal surface, the TH2 Series is capable of handling load currents up to 20 A steady state with 200 A inrush. The TH2 replaces a timer and contactor at a competitive price.

Operation

Upon application of input voltage, the time delay begins. The output is energized during the time delay. At the end of the time delay, the output is de-energized and remains de-energized until input voltage is removed.

Reset: Removing input voltage resets the time delay and output.

Approvals:

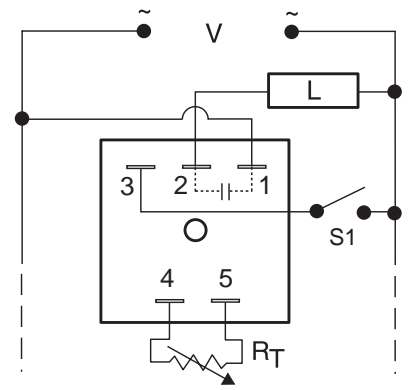

R_T is used when external adjustment is ordered.

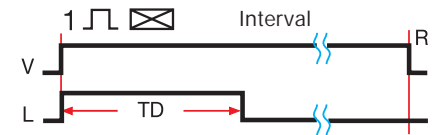

V = Voltage L = Load S1 = Initiate Switch
TD = Time Delay R = Reset
— = Undefined time

Ordering Table

TH2 Series	X Output Rating	X Input	X Adjustment	X Time Delay *
-A	6 A	-2 - 24 V AC	-1 - Fixed	-1 - 0.1 ... 3 s
-B	10 A	-4 - 120 V AC	-2 - External Adjust	-2 - 0.5 ... 60 s
-C	20 A	-6 - 230 V AC		-3 - 2 ... 180 s
				-4 - 5 ... 600 s

* If Fixed Delay is selected, insert delay [0.1 ... 600] in seconds.

Example P/N: TH2C422 Fixed - TH2A410.5

Technical Data

Time Delay	
Type	Analog circuitry
Range	0.1 s ... 600 s in 4 adjustable ranges, or fixed
Repeat Accuracy	$\pm 2\%$
Tolerance (Factory Calibration)	$\leq \pm 10\%$
Time Delay vs. Temperature and Voltage	$\leq \pm 10\%$
Recycle Time	≤ 100 ms
Input	
Voltage	24, 120, or 230 V AC
Tolerance	$\pm 15\%$
Line Frequency	50 ... 60 Hz
Output	
Type	Solid state (zero voltage switching)
Form	Normally Open, closed during timing
Maximum Load Currents	Output Steady State Inrush**
	A 6 A 60 A
	B 10 A 100 A
	C 20 A 200 A
Minimum Load Current	100 mA
Voltage Drop	$\cong 2.0$ V at rated current
Protection	
Circuitry	Encapsulated
Dielectric Breakdown	≥ 2000 V RMS terminals to mounting surface
Insulation Resistance	≥ 100 M Ω
Mechanical	
Mounting **	Surface mount with one #10 (M5 x 0.8) screw
Package	2 x 2 x 1.51 in. (50.8 x 50.8 x 38.4 mm)
Termination	0.25 in. (6.35 mm) male quick connect terminals
Environmental	
Operating Temperature	-20°C ... +60°C
Storage Temperature	-40°C ... +85°C
Humidity	95% relative, non-condensing
Weight	$\cong 3.9$ oz (111 g)

R_T Selection Chart

Desired Time Delay*	Seconds				F
	1	2	3	4	
0.1	0.5	2	5		
0.5	10	30	60		
1.0	20	60	120		
1.5	30	90	180		
2.0	40	120	240		
2.5	50	150	300		
3.0	60	180	360		
			420		
			480		
			540		
			600		

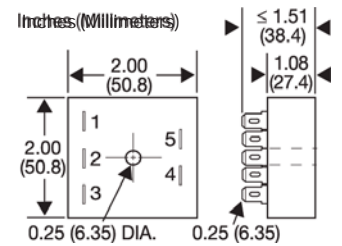

Accessories

Female quick connect



P/N: P1015-64 (AWG 14/16)

External adjust potentiometer

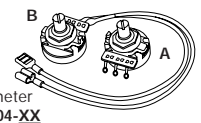

P/N: P1004-XX

Quick connect to screw adaptor

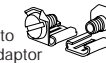

P/N: P1015-18

Plug-on adjustment module



P/N: VTP(X)(X)

Versa-knob



P/N: P0700-7



See accessory pages at the end of this section.

**Must be bolted to a metal surface using the included heat sink compound. The maximum mounting surface temperature is 90°C. Inrush: Non-repetitive for 16 ms.

Time Delay	VTP P/N	Fig. A P/N	Fig. B P/N
1 - 0.1 ... 3 s	VTP4B	P1004-12	P1004-12-X
2 - 0.5 ... 60 s	VTP4F	P1004-12	P1004-12-X
3 - 2 ... 180 s	VTP4J	P1004-12	P1004-12-X
4 - 5 ... 600 s	VTP5N	P1004-13	P1004-13-X