

PCSP Module
NHPD ProgramaCube™
Power Timing Module



Obsolete Specification
 Redesigned product is available
 see new specifications at:
www.ssac.com/standard/standard.htm

- High Load Current
- In Stock
- Choice of Functions
- Microcontroller Timing
- Knob Adjust
- 24 ... 1000 h
- Delays

Description

The NHPD Series is a factory programmed module available with 1 of the available 11 dual functions. The time delays can be factory fixed or adjustable or a combination of fixed and adjustable. Modules are manufactured without the function assigned. When an order is received, the function software is added, making the modules complete. This approach provides fast delivery on all part numbers. The NHPD includes a high current solid state output. It can switch motors, lamps and heaters directly without the addition of a contactor. It can switch up to 20 A with up to 100 million operations typical. Its microcontroller timing circuit provides excellent repeat accuracy and stability. Encapsulation protects against shock, vibration, and humidity. The NHPD Series is a cost effective approach for OEM applications that require small size, long life, and In Stock modules. Special time ranges and functions are available; contact Applications Assistance for more information.

Patent Pending

- Approvals:

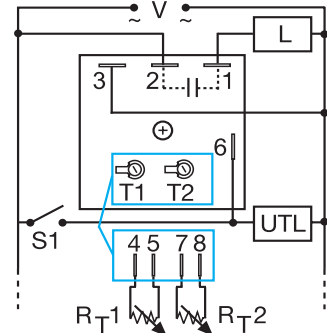

A knob is supplied for adjustable units or R_T terminals for external adjust.

V = Voltage L = Load S1 = Initiate Switch
 UTL = Untimed Load
 T1 & R_{T1} = First Adjustment
 T2 & R_{T2} = Second Adjustment

Ordering Table

NHPD Series	X Output Rating	X Input	X Adjustment	X First Time Delay*	X Adjustment	X Second Time Delay*	X Function **
	-A - 6 A	-2 - 24 V AC	-1 - Fixed	-1 - 0.1 ... 10 s	-1 - Fixed	-1 - 0.1 ... 10 s	Specify Function (Refer to Function Chart for Code)
	-B - 10 A	-4 - 120 V AC	-2 - Knob Adjust	-2 - 1 ... 100 s	-2 - Knob Adjust	-2 - 1 ... 100 s	
	-C - 20 A	-9 - 120/230 V AC	-3 - External Adjust	-3 - 10 ... 1000 s	-3 - External Adjust	-3 - 10 ... 1000 s	
				-4 - 0.1 ... 10 m		-4 - 0.1 ... 10 m	
				-5 - 1 ... 100 m		-5 - 1 ... 100 m	
				-6 - 10 ... 1000 m		-6 - 10 ... 1000 m	
				-7 - 0.1 ... 10 h		-7 - 0.1 ... 10 h	
				-8 - 1 ... 100 h		-8 - 1 ... 100 h	
				-9 - 10 ... 1000 h		-9 - 10 ... 1000 h	

Example P/N: **NHPDA92525MRE**
 Fixed **NHPDB911S15SMB**

*If Fixed Delay is selected, insert delay [0.1 ... 999] followed by (S) secs., (M) mins., or (H) hrs.

Technical Data

Time Delay	Microcontroller circuitry
Type	Microcontroller circuitry
Range	0.1 s ... 1000 h in 9 adjustable ranges or fixed
Repeat Accuracy	+/-1% or 16 ms @ 60 Hz, 20 ms @ 50 Hz, whichever is greater
Tolerance (Factory Calibration)	≤ +/-2%
Recycle Time	≤ 250 ms
Initiate Time	≅ 40 ms
Time Delay vs Temperature & Input Voltage	≤ +/-2%
Input	
Voltage	24, 120, or 120/230 V AC
Tolerance	≤ +/-15%
Line Frequency	50 ... 60 Hz
Output	
Type	Solid state
Rating	Output Steady state Inrush***
	A 6 A 60 A
	B 10 A 100 A
	C 20 A 200 A
Minimum Load Current	100 mA
Voltage Drop	≅ 2.5 V at rated current
Leakage	8.6 mA at 230 V AC 4.5 mA at 120 V AC 0.9 mA at 24 V AC
Protection	
Circuitry	Encapsulated
Dielectric Breakdown	≥ 2000 V RMS terminals to mounting surface
Insulation Resistance	≥ 100 MΩ
Mechanical	
Mounting ***	Surface mount with one #10 (M5 x 0.8) screw
Package (See NHPS for dimensional view)	2 x 2 x 1.51 in. (50.8 x 50.8 x 38.4 mm)
Termination	0.25 in. (6.35 mm) male quick connect terminals
Environmental	
Operating/Storage Temperature	-40°C ... +60°C / -40°C ... +85°C
Humidity	95% relative, non-condensing
Weight	≅ 3.9 oz (111 g)

****Function Chart**

Delay On Make/Delay on Break	MB
Delay On Make/Recycle	MRE
(ON Time First, Equal Times)	
Delay On Make/Interval	MI
Delay On Make/Single Shot	MS
Interval/Recycle (ON Time First, Equal Times)	IRE
Delay On Break/Recycle	BRE
(ON Time First, Equal Times)	
Single Shot/Recycle	SRE
(ON Time First, Equal Times)	
Recycle (Both Times Adjustable, ON Time First)	RXE
Recycle (Both Times Adjustable, OFF Time First)	RXD
Interval/Delay On Make	IM
Accumulative Delay On Make/Interval	AMI

R_T Selection Chart

	Desired Time Delay*									R _T KΩ
	Seconds			Minutes			Hours			
	1	2	3	4	5	6	7	8	9	
0.1	1	10	0.1	1	10	0.1	1	10	0	
1	10	100	1	10	100	1	10	100	10	
2	20	200	2	20	200	2	20	200	20	
3	30	300	3	30	300	3	30	300	30	
4	40	400	4	40	400	4	40	400	40	
5	50	500	5	50	500	5	50	500	50	
6	60	600	6	60	600	6	60	600	60	
7	70	700	7	70	700	7	70	700	70	
8	80	800	8	80	800	8	80	800	80	
9	90	900	9	90	900	9	90	900	90	
10	100	1000	10	100	1000	10	100	1000	100	

* When selecting an external R_T add at least 15% for tolerance of unit and the R_T.

Accessories

	Quick connect to screw adaptor P/N: P1015-18
	Versa-knob P/N: P0700-7
	Female quick connect P/N: P1015-64(AWG14/16)

External adjust potentiometer
 P/Ns: P1004-95 (fig A)
 P1004-95-X (fig B)

See accessory pages at the end of this section.

***Must be bolted to a metal surface using the included heat sink compound. The maximum mounting surface temperature is 90°C. Inrush: Non-repetitive for 16 ms.