

# KSPD Series Dual Function Timing Module

3



US Patent 6708135

10 YEAR WARRANTY

- Choose 1 of 12 Standard Dual Functions
- Special Time Ranges and Functions Available
- Factory Programmed
- Microcontroller Circuitry, +/-0.5% Repeat Accuracy
- 1 A Steady, 10 A Inrush
- 12 ... 240 V in 3 Ranges
- Delays from 100 ms ... 1000 h in 9 Ranges

Approvals:

### Accessories

- External adjust potentiometer  
P/Ns: **P1004-95** (fig A) **P1004-95-X** (fig B)
- Female quick connect  
P/N: **P1015-64** (AWG 14/16)
- Versa-knob  
P/N: **P0700-7**
- Quick connect to screw adaptor  
P/N: **P1015-18**
- DIN rail P/Ns:  
**017322005** (Steel) **C103PM** (Al)
- DIN rail adaptor  
P/N: **P1023-20**

See accessory pages for specifications.

### Description

The KSPD Series is a factory programmed module available with 1 of 12 standard dual functions. The time delays can be factory fixed, externally or onboard adjustable, or a combination of fixed and adjustable. Modules are manufactured without the function assigned. When an order is received, the function software is added, making the modules complete. This approach provides fast delivery on all part numbers. The 1 A steady, 10 A inrush rated solid state output provides 100 million operations, typical. Its microcontroller timing circuit provides excellent repeat accuracy and stability. Encapsulation protects against shock, vibration, and humidity. The KSPD Series is a cost effective approach for OEM applications that require small size and long life. Special time ranges and functions are available, contact Technical Assistance (see below) for more information.

### Connection

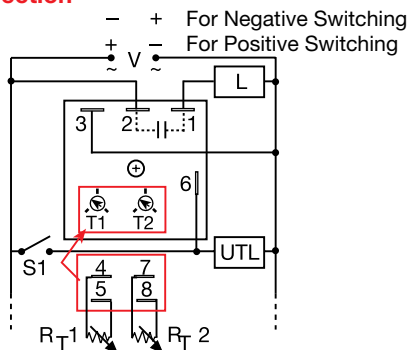

Terminal Location for External Adjustment.

V = Voltage L = Load S1 = Initiate Switch  
UTL = Untimed Load T1 & R<sub>T1</sub> = First Adjustment  
T2 & R<sub>T2</sub> = Second Adjustment

A knob is supplied for adjustable units or R<sub>T</sub> terminals for external adjust. See external adjustment vs time delay chart. The untimed load is optional. S1 is not used for some functions. Dashed lines are internal connections.

### External Resistance vs Time Delay

For details on external R<sub>T</sub> see the external resistance vs. time delay chart at the beginning of this section.

### Mechanical View

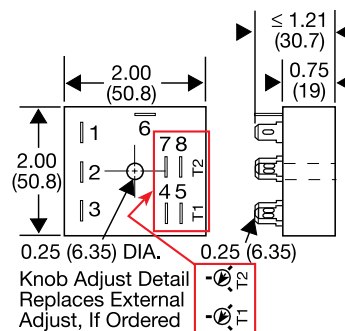

Inches (Millimeters)

### \*\*Function Chart

Delay On Make/Delay on Break	Code
Delay On Make/Recycle (ON Time First, Equal Times)	<b>MB</b>
Delay On Make/Interval	<b>MRE</b>
Delay On Make/Single Shot	<b>MI</b>
Interval/Recycle (ON Time First, Equal Times)	<b>MS</b>
Delay On Break/Recycle (ON Time First, Equal Times)	<b>IRE</b>
Delay On Break/Recycle (ON Time First, Equal Times)	<b>BRE</b>
Single Shot/Recycle (ON Time First, Equal Times)	<b>SRE</b>
Recycle (Both Times Adjustable, ON Time First)	<b>RXE</b>
Recycle (Both Times Adjustable, OFF Time First)	<b>RXD</b>
Interval/Delay On Make	<b>IM</b>
Accumulative Delay On Make/Interval	<b>AMI</b>
Single Shot/Lockout	<b>SL</b>

For a Complete List of Functions with Descriptions, see Timer Function Section.

KSPD Series	X Input	X First Adjustment (T1 or R <sub>T1</sub> )	X First Time Delay*	X Second Adjustment (T2 or R <sub>T2</sub> )	X Second Time Delay*	X Function**
	<b>A</b> - 24 ... 240 V AC	<b>1</b> - Fixed	<b>1</b> - 0.1 ... 10 s	<b>1</b> - Fixed	<b>1</b> - 0.1 ... 10 s	**Specify Function (Refer to Function Chart for Code)  *If Fixed Delay is selected, insert delay [0.1 ... 999] followed by (S) secs., (M) mins., or (H) hrs.
	<b>P</b> - 12 ... 120 V DC Positive Switching	<b>2</b> - Onboard Adjust	<b>2</b> - 1 ... 100 s	<b>2</b> - Onboard Adjust	<b>2</b> - 1 ... 100 s	
	<b>N</b> - 12 ... 120 V DC Negative Switching	<b>3</b> - External Adjust	<b>3</b> - 10 ... 1000 s	<b>3</b> - External Adjust	<b>3</b> - 10 ... 1000 s	
			<b>4</b> - 0.1 ... 10 m		<b>4</b> - 0.1 ... 10 m	
			<b>5</b> - 1 ... 100 m		<b>5</b> - 1 ... 100 m	
			<b>6</b> - 10 ... 1000 m		<b>6</b> - 10 ... 1000 m	
			<b>7</b> - 0.1 ... 10 h		<b>7</b> - 0.1 ... 10 h	
			<b>8</b> - 1 ... 100 h		<b>8</b> - 1 ... 100 h	
			<b>9</b> - 10 ... 1000 h		<b>9</b> - 10 ... 1000 h	

Example P/N: **KSPDA2525MRE** Fixed - **KSPDP10.5S15SMB**

# KSPD Series Timing Module

## Technical Data

<b>Time Delay</b> Type Range Repeat Accuracy Tolerance (Factory Calibration) Reset Time Initiate Time Time Delay / Temp. & Voltage	Microcontroller circuitry 0.1 s ... 1000 h in 9 adjustable ranges or fixed (to 999) +/-0.5% or 20 ms, whichever is greater ≤ +/-2% ≤ 150 ms ≤ 20 ms; ≤ 1500 operations per minute ≤ +/-2%	<b>Protection</b> Circuitry Dielectric Breakdown Insulation Resistance Polarity	Encapsulated ≥ 2000 V RMS terminals to mounting surface ≥ 100 MΩ DC units are reverse polarity protected
<b>Input</b> Voltage Tolerance Line Frequency/DC Ripple Power Consumption	12 ... 120 V DC; 24 ... 240 V AC ≤ +/-15% 50 ... 60 Hz/≤ 10% AC ≤ 2 VA; DC ≤ 1 W	<b>Mechanical</b> Mounting Package Termination	Surface mt. with one #10 (M5 x 0.8) screw 2 x 2 x 1.21 in. (50.8 x 50.8 x 30.7 mm) 0.25 in. (6.35 mm) male quick connects
<b>Output</b> Type Rating Voltage Drop OFF State Leakage Current	Solid state output 1 A steady, 10 A inrush for 16 ms AC ≅ 2.5 V at 1 A; DC ≅ 1 V at 1 A AC ≅ 5 mA at 230 V AC; DC ≅ 1 mA	<b>Environmental</b> Operating Temperature Storage Temperature Humidity Weight	-40°C ... +60°C -40°C ... +85°C 95% relative, non-condensing ≅ 2.4 oz (68 g)

## Function Diagrams

For a Complete List of Functions with Descriptions, see Timer Function Section.

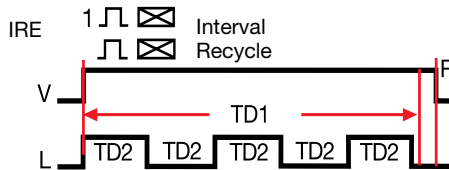
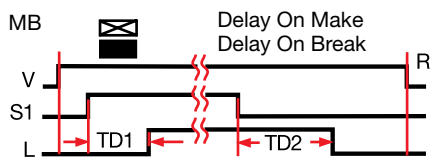

RXD

Same as RXE except OFF Time is first.

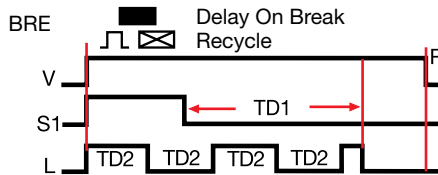
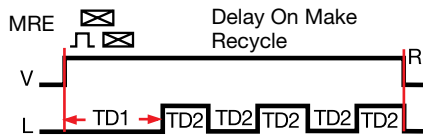

IM

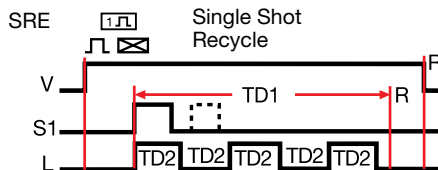
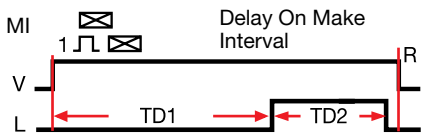
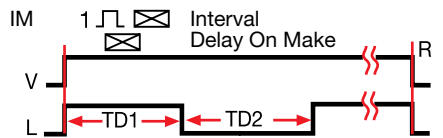

AMI

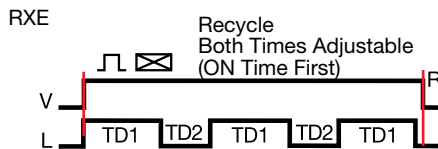
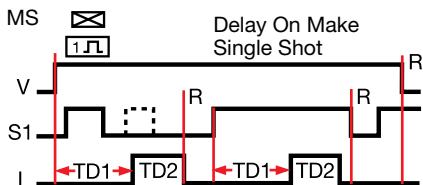
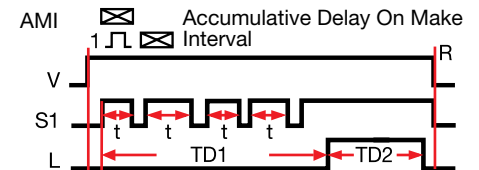

SL

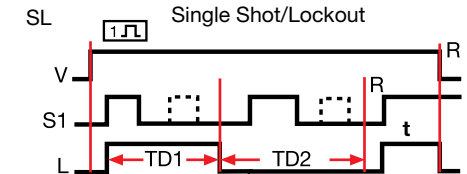

## Legend

- V Voltage
- R Reset
- S1 Initiate Switch
- L Load
- TD1, TD2 Time Delay
- t Incomplete Time Delay
- }— Undefined time

Note: If S1 is closed when input voltage is applied, the function starts and the time delay begins. (MB, MS, BRE, SRE, AMI, SL)