

Motion Detector KRD9 Digi-Timer Time Delay Relay



Obsolete Specification
Redesigned product is available
see new specifications at:
www.ssc.com/standard/standard.htm

- Compact Design
- Microcontroller based Repeat Accuracy
- Isolation between contacts
- Onboard Fixed Time Delay
- Delays from 0.1 to 1000 m
- Input Voltage 12 ... 120 V in 5 Ranges

Description

The KRD9 Series microcontroller timing circuit provides excellent repeat accuracy and stability. Cost effective approach for OEM applications that require small size, isolation, reliability, and long life.

Operation - Retriggerable Single Shot

Mode Type A (Output Initially De-energized): Input voltage must be applied prior to and during timing. When the initiate switch is closed, (momentary or maintained) the output is energized and the time delay is started. On completion of the delay, the output is de-energized. Reclosing the initiate switch resets the time delay and restarts timing; the output remains energized.

Mode Type B (Output Initially Energized): Upon application of input voltage, the output is energized and the time delay is started. At the end of the time delay, the load is de-energized. Closing (re-closing) the initiate switch resets the time delay and restarts timing; the output remains energized.

Reset: The time delay and the output are reset when input voltage is removed.

- Approvals:

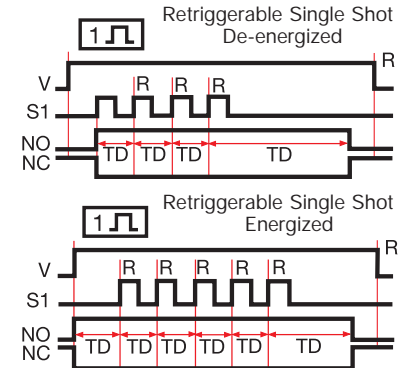
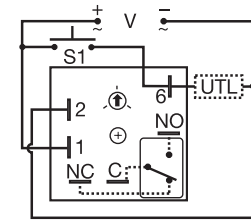

V = Voltage S1 = Initiate Switch R = Reset
UTL = Untimed Load TD = Time Delay
NO = Normally Open NC = Normally Closed

Ordering Table

KRD9 Series	Input	Adjustment	Time Delay *	Mode
-1	12 V DC	-1 - Fixed	0 - 0.1 ... 10 s	A - De-energized
-2	24 V AC/DC	-2 - Onboard Adjustment	1 - 1 ... 100 s	B - Energized
-4	120 V AC		2 - 10 ... 1000 s	
-5	110 V DC		3 - 0.1 ... 10 m	
			4 - 1 ... 100 m	
			5 - 10 ... 1000 m	

* If Fixed Delay is selected, insert delay [0.1 ... 1000] followed by (S) sec. or (M) min.

Example P/N: **KRD9421A**
Fixed - **KRD94110MB**

Technical Data

Time Delay	
Type	Microcontroller based with watchdog circuitry
Range	0.1 s ... 1000 m in 6 adjustable ranges or fixed
Repeat Accuracy	+/-1% or 16 ms @ 60 Hz, 20 ms @ 50 Hz, whichever is greater
Tolerance (Factory Calibration)	≤ +/-10%
Recycle Time	≤ 250 ms
Initiate Time	AC: ≅ 40 ms, DC: ≅ 10 ms
Maximum Number of Initiates per Minute	AC units: 400 per minute DC units: 500 per minute
Time Delay vs. Temperature & Voltage	≤ +/-5%
Input	
Voltage	12, 24 or 110 V DC; 120 V AC; 24 V AC/DC
Tolerance	12 V DC & 24 V DC/AC: -15% ... +20% 110 ... 240 V AC/DC: -20% ... +10%
Line Frequency	50 ... 60 Hz
Power Consumption	12, 24 V DC: ≤ 1 W; 24 V AC: ≤ 1 V A; 110 V DC: ≤ 2 W; 120 V AC: ≤ 2 V A
Output	
Type	Isolated relay contacts
Form	Single pole double throw (SPDT)
Rating (at 40°C)	10 A resistive at 125 V AC 5 A resistive at 30 V DC; 1/4 hp at 125 V AC
Life	Mechanical -- 1 x 10 ⁷ Electrical -- 1 x 10 ⁵ for 10 A at 120 V AC
Protection	
Circuitry	Encapsulated
Isolation Voltage	≥ 1500 V RMS input to output
Insulation Resistance	≥ 100 MΩ
Polarity	DC units are reversed polarity protected
Mechanical	
Mounting	Surface mount with one #10 (M5 x 0.8) screw
Package	2 x 2 x 1.21 in. (50.8 x 50.8 x 30.7 mm)
Termination	0.25 in. (6.35 mm) male quick connect terminals
Environmental	
Operating Temperature	-40°C ... +60°C
Storage Temperature	-40°C ... +85°C
Humidity	95% relative, non-condensing
Weight	≅ 2.6 oz (74 g)

Output Current / Ambient Temp.

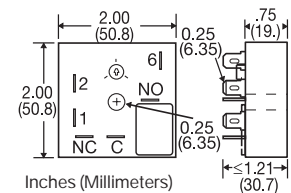
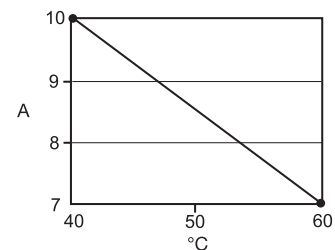

Accessories

Female quick connect

P/N: P1015-64 (AWG14/16)

Quick connect to screw adaptor
P/N: P1015-18

Mounting bracket
P/N: P1023-6

DIN rail P/Ns:
17322005 (Steel)
C103PM (Al)
DIN rail adaptor
P/N: P1023-20

See accessory pages at the end of this section.