

Delay On Make HRDM Power-Time Time Delay Relay



5

- 30 A SPDT N.O. Output Contact
- 12 ... 230 V Operation in 5 Ranges
- Encapsulated Circuitry
- Delays from 100 ms ... 100 m in 5 Ranges
- +/-0.5% Repeat Accuracy
- Fixed, External, or Onboard Adjustment

Approvals:

Accessories

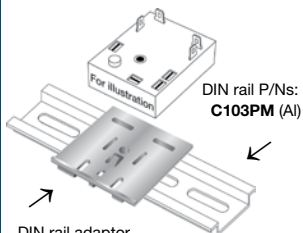
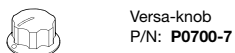
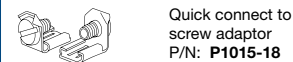
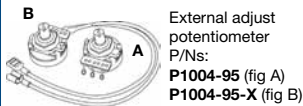

DIN rail adaptor
P/N: P1023-20

See accessory pages for specifications.

Description

The HRDM Series combines an electromechanical relay output with microcontroller timing circuitry. It offers 12 to 230 V operation in five ranges and factory fixed, external, or onboard adjustable time delays with a repeat accuracy of +/-0.5%. The output contact rating allows for direct operation of heavy loads such as compressors, pumps, blower motors, heaters, etc. This series is ideal for OEM applications where cost is a factor.

Operation

Upon application of input voltage, the time delay begins. The output is de-energized before and during the time delay. At the end of the time delay, the output relay energizes and remains energized until input voltage is removed.

Reset: Removing input voltage resets the time delay and output.

Function

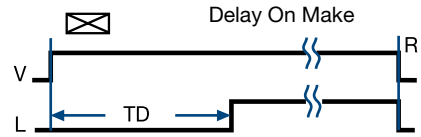

V = Voltage L = Load R = Reset
TD = Time Delay = Undefined time

Connection

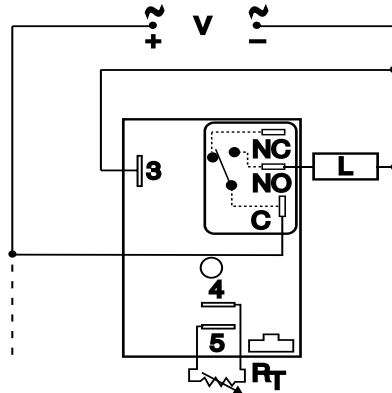

NO = Normally Open L = Load
C = Common, Transfer Contact

NOTE: A knob, or terminals 4 & 5 are only included on adjustable units. R_T is used when external adjustment is ordered. Relay contacts are not isolated. Dashed lines are internal connections.

Available Models-

HRDM1112S	HRDM113S	HRDM120
HRDM21180S	HRDM3112S	HRDM413M
HRDM415M	HRDM420	HRDM421
HRDM423	HRDM424	HRDM623

Don't see what you need? Call us for a minimum quantity and price quote!

Ordering Table

HRDM Series	X Input	X Adjustment	X Time Tolerance	X Time Delay *
	-1 - 12 V DC	-1 Fixed	-A - +/-1%	-0 - 0.1 ... 10 s
	-2 - 24 V AC	-2 Onboard Knob	Blank - +/-5%	-1 - 1 ... 100 s
	-3 - 24 V DC	-3 External Adjust		-2 - 10 ... 1000 s
	-4 - 120 V AC			-3 - 0.1 ... 10 m
	-6 - 230 V AC			-4 - 1 ... 100 m

HRDM421 Fixed – HRDM41A0.5S

* If Fixed Delay is selected, insert delay [0.1 ... 1000] followed by (S) sec. or [0.1 ... 100] (M) min.

Delay On Make HRDM Power-Time Time Delay Relay

Dedicated
timers

Technical Data

Time Delay		Microcontroller circuitry	
Type		100 ms ... 100 m in 5 adjustable ranges or fixed	
Range		+/-0.5% or 20 ms, whichever is greater	
Repeat Accuracy		+/-1%, +/-5%	
Tolerance (Factory Calibration)		≤ 150 ms	
Reset Time		+/-2%	
Time Delay vs. Temperature & Voltage			
Input			
Voltage		12 or 24 V DC; 24, 120, or 230 V AC	
Tolerance	12 V DC & 24 V DC	-15% ... +20%	
	24 ... 230 V AC	-20% ... +10%	
Line Frequency		50 ... 60 Hz	
Power Consumption		AC ≤ 4 VA; DC ≤ 2 W	
Output			
Type		Electromechanical relay	
Form		SPDT, non-isolated	
Ratings:		SPDT-N.O.	SPDT-N.C.
General Purpose	125/240 V AC	30 A	15 A
Resistive	125/240 V AC	30 A	15 A
	28 V DC	20 A	10 A
Motor Load	125 V AC	1 hp*	1/4 hp**
	240 V AC	2 hp**	1 hp**
Life		Mechanical -- 1 x 10 ⁶ ; Electrical -- 1 x 10 ⁵ , *3 x 10 ⁴ , **6,000	
Protection			
Surge		IEEE C62.41-1991 Level A	
Circuitry		Encapsulated	
Dielectric Breakdown		≥ 2000 V RMS terminals to mounting surface	
Insulation Resistance		≥ 100 MΩ	
Polarity		DC units are reverse polarity protected	
Mechanical			
Mounting		Surface mount with one #10 (M5 x 0.8) screw	
Package		3 x 2 x 1.5 in. (76.7 x 51.3 x 38.1mm)	
Termination		0.25 in. (6.35 mm) male quick connect terminals	
Environmental			
Operating / Storage Temperature		-40°C ... +60°C / -40°C ... +85°C	
Humidity		95% relative, non-condensing	
Weight		≈ 3.9 oz (111 g)	

5

External Resistance vs Time Delay In Secs. or Mins.

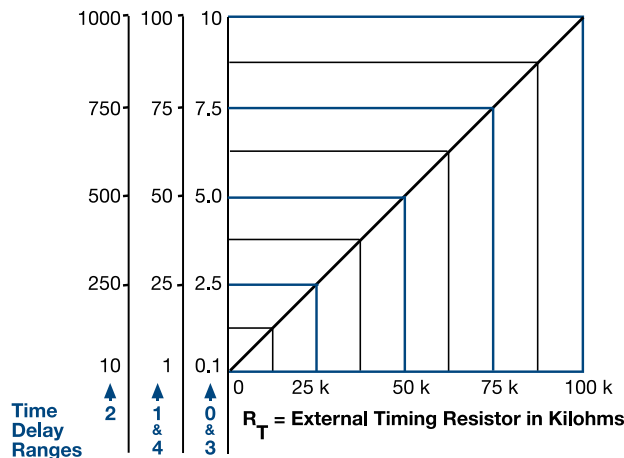

This chart applies to externally adjustable part numbers.
The time delay is adjustable over the time delay range selected by varying the resistance across the R_T terminals; as the resistance increases the time delay increases.
When selecting an external R_T, add the tolerances of the timer and the R_T for the full time range adjustment.
Examples: 1 to 50 S adjustable time delay, select time delay range 1 and a 50 K ohm R_T. For 1 to 100 S use a 100 K ohm R_T.

Mechanical View

