

Delay On Break (Release) HRDB Power-Time Time Delay Relay



- 30 A SPDT N.O. Isolated Output Contacts
- 12 ... 230 V Operation in 5 Ranges
- Delays from 100 ms ... 100 m in 5 Ranges
- +/-0.5% Repeat Accuracy
- Fixed, External, or Onboard Adjustment

Approvals:

Accessories

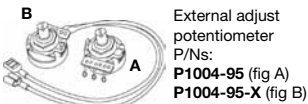

External adjust potentiometer P/Ns:
P1004-95 (fig A)
P1004-95-X (fig B)



Mounting bracket P/N: P1023-6



Female quick connect P/Ns:
P1015-64 (AWG 14/16)
P1015-13 (AWG 10/12)

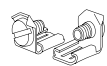

Quick connect to screw adaptor P/N: P1015-18



Versa-knob P/N: P0700-7

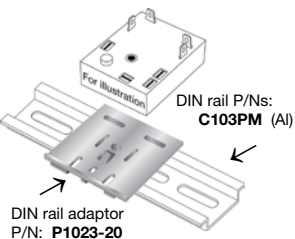

DIN rail P/Ns: C103PM (AI)

DIN rail adaptor P/N: P1023-20

See accessory pages for specifications.

Description

The HRDB Series combines an electromechanical relay output with microcontroller timing circuitry. The HRDB offers 12 to 230 V operation in five ranges and factory fixed, external, or onboard adjustable time delays with a repeat accuracy of +/-0.5%. The isolated output contact rating allows for direct operation of heavy loads such as compressors, pumps, blower motors, heaters, etc. The HRDB is ideal for OEM applications where cost is a factor.

Operation

Input voltage must be applied before and during timing. Upon closure of the initiate switch, the output relay energizes. The time delay begins when the initiate switch is opened. The output remains energized during timing. At the end of the time delay, the output de-energizes. The output will energize if the initiate switch is closed when input voltage is applied.

Reset: Reclosing the initiate switch during timing resets the time delay. Loss of input voltage resets the time delay and output.

Function

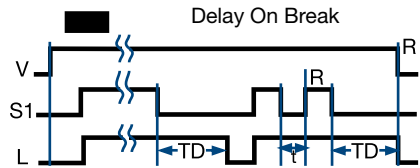

V = Voltage L = Load S1 = Initiate Switch
TD = Time Delay R = Reset
t = Incomplete Time Delay
— = Undefined time

Connection

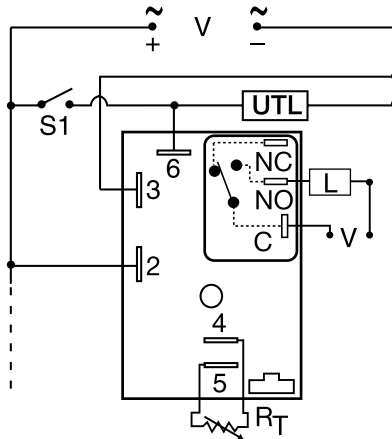

S1 = Initiate Switch L = Timed Load
UTL = Untimed Load NO = Normally Open
C = Common, Transfer Contact

NOTE: A knob, or terminals 4 & 5 are only included on adjustable units. R_t is used when external adjustment is ordered. Relay contacts are isolated. Dashed lines are internal connections. The un-timed load is optional.

Available Models-

HRDB1110M	HRDB1110S	HRDB111M
HRDB1130M	HRDB113S	HRDB120
HRDB121	HRDB122	HRDB124
HRDB21A65M	•HRDB223	HRDB315M
HRDB321	HRDB324	HRDB4130S
•HRDB423	HRDB424	HRDB6130M
•HRDB623		

Don't see what you need? Call us for a minimum quantity and price quote!

Ordering Table

HRDB Series	X Input	X Adjustment	X Time Tolerance	X Time Delay*
	-1 - 12 V DC	-1 - Fixed	-A - +/-1%	-0 - 0.1 ... 10 s
	-2 - 24 V AC	-2 - Onboard Knob	Blank - +/-5%	-1 - 1 ... 100 s
	-3 - 24 V DC	-3 - External Adjust		-2 - 10 ... 1000 s
	-4 - 120 V AC			-3 - 0.1 ... 10 m
	-6 - 230 V AC			-4 - 1 ... 100 m

* If Fixed Delay is selected, insert delay [0.1 ... 1000] followed by (S) sec. or [0.1 ... 100] (M) min.

Example P/N: HRDB421 Fixed - HRDB41A0.5S

Delay On Break (Release) HRDB Power-Time Time Delay Relay

Dedicated
timers

Technical Data

Time Delay		
Type		Microcontroller circuitry
Range		100 ms ... 100 m in 5 adjustable ranges or fixed
Repeat Accuracy		+/-0.5 % or 20 ms, whichever is greater
Tolerance (Factory Calibration)		+/-1%, +/-5%
Reset Time		≤ 150 ms
Initiate Time		≤ 20 ms
Time Delay vs. Temperature & Voltage		+/-2%
Input		
Voltage		12 or 24 V DC; 24, 120, or 230 V AC
Tolerance	12 V DC & 24 V DC 24 ... 230 V AC	-15% ... +20% -20% ... +10%
Line Frequency		50 ... 60 Hz
Power Consumption		AC ≤ 4 VA; DC ≤ 2 W
Output		
Type		Electromechanical relay
Form		SPDT, isolated
Ratings:		SPDT-N.O. SPDT-N.C.
General Purpose	125/240 V AC	30 A 15 A
Resistive	125/240 V AC	30 A 15 A
	28 V DC	20 A 10 A
Motor Load	125 V AC	1 hp* 1/4 hp**
	240 V AC	2 hp** 1 hp**
Life		Mechanical -- 1 x 10 ⁶ ; Electrical -- 1 x 10 ⁵ , *3 x 10 ⁴ , **6,000
Protection		
Surge		IEEE C62.41-1991 Level A
Circuitry		Encapsulated
Dielectric Breakdown		≥ 2000 V RMS terminals to mounting surface
Insulation Resistance		≥ 100 MΩ
Polarity		DC units are reverse polarity protected
Mechanical		
Mounting		Surface mount with one #10 (M5 x 0.8) screw
Package		3 x 2 x 1.5 in. (76.7 x 51.3 x 38.1mm)
Termination		0.25 in. (6.35 mm) male quick connect terminals
Environmental		
Operating/Storage Temperature		-40°C ... +60°C/-40°C ... +85°C
Humidity		95% relative, non-condensing
Weight		≅ 3.9 oz (111 g)

5

External Resistance vs Time Delay In Secs. or Mins.

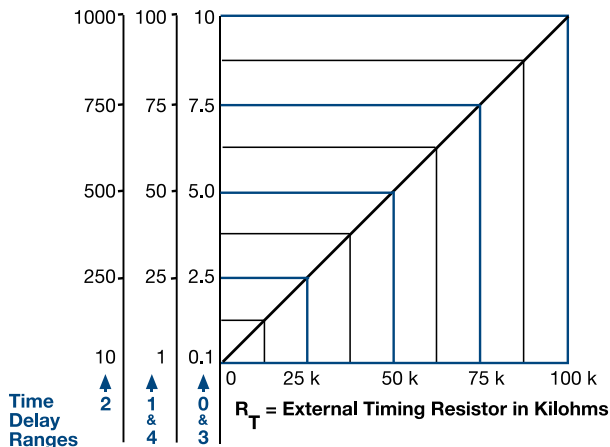

This chart applies to externally adjustable part numbers. The time delay is adjustable over the time delay range selected by varying the resistance across the R_T terminals; as the resistance increases the time delay increases. When selecting an external R_T , add the tolerances of the timer and the R_T for the full time range adjustment. **Examples:** 1 to 50 S adjustable time delay, select time delay range 1 and a 50 K ohm R_T . For 1 to 100 S use a 100 K ohm R_T .

Mechanical View

