

Recycling (Flasher) HRD3 Power-Time Time Delay Relay



5

- Equal ON and OFF Delays
- 30 A SPDT N.O. Output Contacts
- 12 ... 230 V Operation in 5 Ranges
- Encapsulated Circuitry
- Delays from 100 ms ... 100 m in 5 Ranges
- +/-0.5% Repeat Accuracy
- Fixed, External, or Onboard Adjustment

Approvals:

Accessories

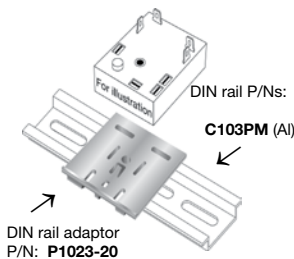
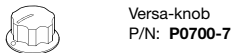
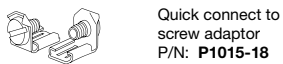
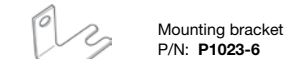
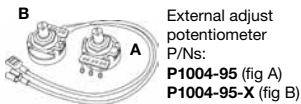

See accessory pages for specifications.

Description

The HRD3 Series combines an electromechanical relay output with microcontroller timing circuitry. It offers 12 to 230 V operation in five ranges and factory fixed, external, or onboard adjustable time delays with a repeat accuracy of +/-0.5%. The output contact rating allows for direct operation of heavy loads such as compressors, pumps, blower motors, heaters, etc. This series is ideal for OEM applications where cost is a factor.

Operation (ON Time First)

Upon application of input voltage, the output relay energizes and the T1 ON time begins. At the end of the ON time, the output de-energizes and the T2 OFF time begins. At the end of the OFF time, the output relay energizes and the cycle repeats as long as input voltage is applied.

Reset: Removing input voltage resets the output and time delays, and returns the sequence to the first delay.

Operation (OFF Time First)

Upon application of input voltage, the T2, OFF time begins. At the end of the OFF time, the T1, ON time begins and the load energizes. At the end of the ON time the load de-energizes, and the cycle repeats until input voltage is removed.

Reset: Removing input voltage resets the output and the sequence to the OFF time.

Function

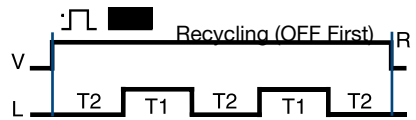
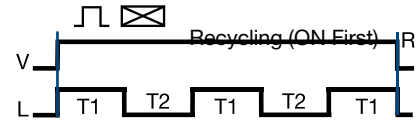

V = Voltage R = Reset L = Load
T1 = ON Time T2 = OFF Time

Connection

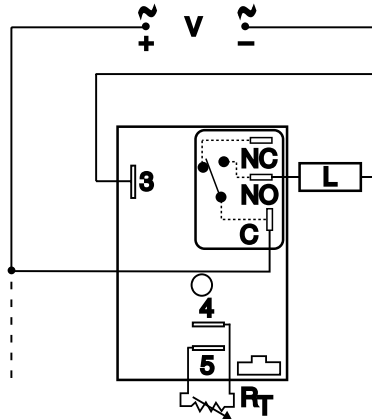

C = Common, Transfer Contact
NO = Normally Open L = Load

NOTE: A knob, or terminals 4 & 5 are only included on adjustable units. Rt is used when external adjustment is ordered. Relay contacts are not isolated. Dashed lines are internal connections.

Available Models-

HRD3120A
HRD3631A

HRD3424A

HRD342A0A

Don't see what you need? Call us for a minimum quantity and price quote!

Ordering Table

HRD3 Series	X Input	X Adjustment	X Time Tolerance	X Time Delay *	X Operating Sequence
	-1 - 12 V DC	-1 - Fixed	-A - +/-1%	-0 - 0.1 ... 10 s	-A - ON
	-2 - 24 V AC	-2 - Onboard Knob	Blank - +/-5%	-1 - 1 ... 100 s	Time First
	-3 - 24 V DC	-3 - External Adjust		-2 - 10 ... 1000 s	-B - OFF
	-4 - 120 V AC			-3 - 0.1 ... 10 m	Time First
	-6 - 230 V AC			-4 - 1 ... 100 m	

* If Fixed Delay is selected, insert delay [0.1 ... 1000] followed by (S) sec. or [0.1 ... 100] (M) min.

Example P/N: HRD3421A Fixed - HRD341A0.5SB

Recycling (Flasher) HRD3 Power-Time Time Delay Relay

Dedicated
timers

Technical Data

Time Delay		
Type		Microcontroller circuitry
Range		100 ms ... 100 m in 5 adjustable ranges or fixed
Repeat Accuracy		+/-0.5 % or 20 ms, whichever is greater
Tolerance (Factory Calibration)		+/-1%, +/-5%
Reset Time		≤ 150 ms
Time Delay vs. Temperature & Voltage		+/-2%
Input		
Voltage		12 or 24 V DC; 24, 120, or 230 V AC
Tolerance	12 V DC & 24 V DC	-15% ... +20%
	24 ... 230 V AC	-20% ... +10%
Line Frequency		50 ... 60 Hz
Power Consumption		AC ≤ 4 VA; DC ≤ 2 W
Output		
Type		Electromechanical relay
Form		SPDT, non-isolated
Ratings:		SPDT-N.O. SPDT-N.C.
General Purpose	125/240 V AC	30 A 15 A
Resistive	125/240 V AC	30 A 15 A
	28 V DC	20 A 10 A
Motor Load	125 V AC	1 hp* 1/4 hp**
	240 V AC	2 hp** 1 hp**
Life		Mechanical -- 1 x 10 ⁶ ; Electrical -- 1 x 10 ⁵ , *3 x 10 ⁴ , **6,000
Protection		
Surge		IEEE C62.41-1991 Level A
Circuitry		Encapsulated
Dielectric Breakdown		≥ 2000 V RMS terminals to mounting surface
Insulation Resistance		≥ 100 MΩ
Polarity		DC units are reverse polarity protected
Mechanical		
Mounting		Surface mount with one #10 (M5 x 0.8) screw
Package		3 x 2 x 1.5 in. (76.7 x 51.3 x 38.1 mm)
Termination		0.25 in. (6.35 mm) male quick connect terminals
Environmental		
Operating / Storage Temperature		-40°C ... +60°C / -40°C ... +85°C
Humidity		95% relative, non-condensing
Weight		≅ 3.9 oz (111 g)

5

External Resistance vs Time Delay In Secs. or Mins.

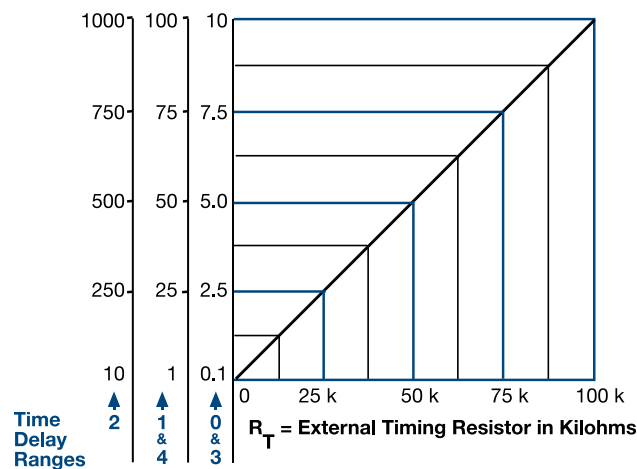

Mechanical View

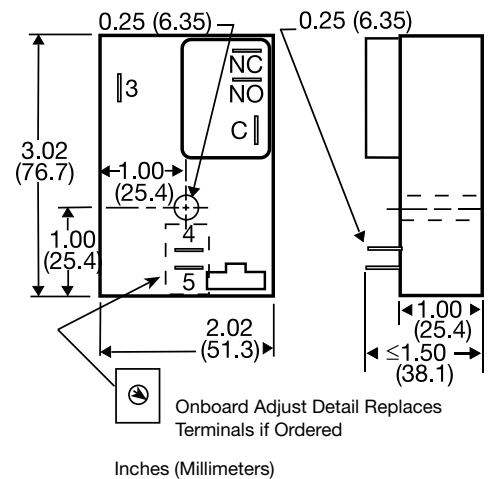

This chart applies to externally adjustable part numbers.

The time delay is adjustable over the time delay range selected by varying the resistance across the R_T terminals; as the resistance increases the time delay increases.

When selecting an external R_T, add the tolerances of the timer and the R_T for the full time range adjustment.

Examples: 1 to 50 S adjustable time delay, select time delay range 1 and a 50 K ohm R_T. For 1 to 100 S use a 100 K ohm R_T.