

# Universal 3 Phase Voltage Monitor HLMU Series (DPDT) Motor Protector



ANSI Device #27/47/59



- Protects Against: Phase Loss, Phase Reversal, Over, Under & Unbalanced Voltages, Over/Under Frequency
- Encapsulated Circuitry
- DPDT Isolated 10 A Contacts
- LED Indicates Relay Status, Faults, & Time Delays
- Universal Line Voltage 200 ... 480 V AC in One Unit
- Compact, Encapsulated Design
- Finger-Safe Terminal Blocks, up to 12 AWG
- ASME A17.1 rule 210.6
- NEMA MG1 14:30, 14:35
- IEEE C62.41-1991 Level B

Approvals: LISTED

### Accessories

- 3-phase fuse block/disconnect  
P/N: **P0700-241**
  - 2 Amp Fuse  
P/N: **P0600-11**
  - DIN rail P/Ns:  
**017322005 (Steel)**  
**C103PM (Al)**
  - DIN rail adaptor  
P/N: **P1023-20**
- See accessory pages for specifications.

### Description

The HLMU Series is a universal voltage, encapsulated, 3 Phase Voltage Monitor. It continuously measures the voltage of each of the three phases with microcontroller accuracy and compares the value to preset trip points. It separately senses Phase Reversal, Over, Under and Unbalanced voltages including Phase Loss and over or under frequency. Protection is assured during periods of large average voltage fluctuations, or when regenerated voltages are present. The unit trips within 200 ms when phase loss is detected. Adjustable time delays are included to prevent nuisance tripping and short cycling of sensitive equipment. The 10A isolated DPDT output relay contacts trip when a phase voltage exceeds the trip limits for the trip delay. Nominal line voltage, voltage unbalance, and time delays are knob adjustable. The phase loss set point and the acceptable frequency range are fixed. Both Delta and Wye systems can be monitored; no connection to neutral is required.

### Operation

Upon application of line voltage, the output is de-energized and the restart delay begins. If all the three phase voltages are within the acceptable range, the output energizes at the end of the restart delay. The microcontroller circuitry automatically senses the voltage range, and selects the correct operating frequency (50 or 60hz). The over and under voltage trip points are set at +/- 10% of the adjusted line voltage. When the measured value of any phase voltage exceeds the acceptable range limits (lower or upper) the trip delay begins. At the end of the trip delay the output relay de-energizes. If the phase voltage returns to an acceptable value before the trip delay expires, the trip delay is reset and the output remains energized. Under, over, and unbalanced voltages plus over or under frequency must be sensed for the complete trip delay before the unit trips. The unit trips in 200 ms when phase loss or reversal are sensed. The unit will not energize if a fault is sensed as the line voltage is applied.

**Reset:** Reset is automatic upon correction of the voltage or frequency fault or phase sequence.

### Connection

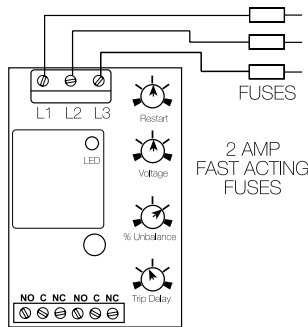

**CAUTION:** 2 amp max. fast acting fuses are recommended to protect the equipment's wiring. They are not required to protect the HLMU.

L1, L2, L3 = Line Voltage Input  
NO = Normally Open Contact NC = Normally Closed Contact  
C = Common, Transfer Contact

**Note:** Relay contacts are isolated, 277 V AC max.

### Restart Delay Options:

**L= Lockout or minimum OFF time.** The restart delay begins when the output trips. The unit cannot be re-energized until the restart delay is complete. This provides a minimum off time or lockout time to allow equipment sensitive to short cycling, time to reset. If the fault is corrected after the restart delay is complete, the output energizes immediately. The restart delay also occurs when line voltage is applied/reapplied.

**R= Restart Delay on fault correction.** The restart delay begins when line voltage is reapplied or when a voltage fault is corrected. This option is normally selected when staggered restarting of multiple motors on a power system is required.

**N= No Restart Delay.** 0.6 second initialization delay on application of line voltage applies.

### Restart Notes:

All restart options remain reset when the following conditions are detected:

- 1.) Phase Loss (phase unbalance greater than 25%)
- 2.) Average Line Voltage less than 120VAC
- 3.) Phase Reversal

The restart delay begins when the condition is corrected.

### LED Operation

The LED flashes green during the restart delay, then glows green when the output energizes. It flashes red during the trip delay then glows red when the output de-energizes. It flashes red/green if phase reversal is sensed. If a fault is sensed during the restart delay, the LED will glow red during that portion or the full restart delay.

### LED Flashing Table

Trip Delay	Red	ON/OFF	120 FPM
Restart Delay	Green	ON/OFF	60 FPM
Phase Reversal	Red/Green	Alternate	120 FPM

FPM = Flashes per minute

### Ordering Table

HLMU Series	X Output	X Restart Function	X Voltage Unbalance	X Trip Delay	X Restart Delay
	D - DPDT	L - Lockout, Min Off Time R - Staggered Restarting N - No Restart Delay	A - Adjustable 2 ...10% Fixed: Specify Unbalance 2 ...10% in 1% increments, using 2 digits [04]	A - Adjustable 1...30 s Fixed: Specify delay 1 ... 30 s in 1 s increments, using 2 digits, [05]	A - Adjustable 0.6 ...300 s ① N - No Restart Delay

### Example P/N:

- HLMUDLAAA** = 200 ... 480 V, DPDT, Lockout Restart, Adjustable Unbalance, Trip and Restart Delay
- HLMUDNAAN** = 200 ... 480 V, DPDT, No Restart Delay, Adjustable Unbalance and Trip Delay
- HLMUDRAAA** = 200 ... 480 V, DPDT, Staggered Restart, Adjustable Unbalance, Trip and Restart Delay
- HLMUDL0405A** = 200 ... 480, DPDT, Lockout Restart, Fixed Unbalance 4%, Fixed Trip Delay 5 Seconds, Adjustable Restart

① Selection "A" is only available for Restart functions "L" and "R"

# Universal 3 Phase Voltage Monitor HLMU Series (DPDT) Motor Protector

Voltage  
Monitors

## Technical Data

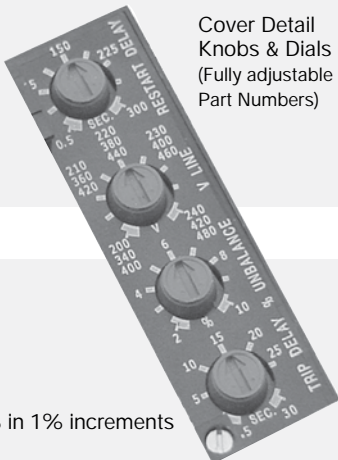
<b>Line Voltage</b>		3 phase Delta or Wye with no connection to neutral <b>Range Voltage Adjustment Range Line Frequency</b> 240 200 ... 240 V AC 50 or 60 Hz 380 340 ... 420 V AC 50 Hz 480 400 ... 480 V AC 60 Hz		Cover Detail Knobs & Dials (Fully adjustable Part Numbers)
Type				
Operating Voltage	200 ... 480 V AC			
Line Voltage Max.		550 V AC		
Line Frequency		50 or 60 Hz Automatically detected		
<b>Phase Loss</b>		≥ 25% Unbalance		
	Response Time	≤ 200ms		
<b>Undervoltage and Voltage Unbalance</b>		Voltage detection with delayed trip & automatic reset Type Overvoltage: Trip Voltage 109 to 113% of the adjusted line voltage Reset Voltage ≅ -3% of the trip voltage Undervoltage: Trip Voltage 88 ... 92% of the adjusted line voltage Reset Voltage ≅ +3% of the trip voltage Voltage Unbalance: Trip Set Point Adjustable 2 ... 10%; or specify fixed unbalance of 2 ... 10% in 1% increments Reset on Balance ≅ -0.7% Unbalance Trip Delay Active On Over/Undervoltage, Voltage Unbalance, Over/Under Frequency Range Adjustable from 1 ... 30 s; or specify fixed delay 1 ... 30 s in 1 s increments Tolerance ± 15% Restart Delay Range Adjustable from 0.6 ... 300 s; if no restart delay is selected a 0.6 s initialization delay applies Tolerance ± 15% Over/Under Frequency Trip / Reset ± 4%; Reset ± 3%; 50 or 60 Hz Phase Sequence A, B, C, L1, L2, L3 Response Time-Phase Reversal & Phase Loss ≤ 200 ms Reset Automatic		
Type				
Overvoltage:	Trip Voltage			
	Reset Voltage			
Undervoltage:	Trip Voltage			
	Reset Voltage			
Voltage Unbalance:	Trip Set Point			
	Reset on Balance			
Trip Delay	Active On			
	Range			
	Tolerance			
Restart Delay	Range			
	Tolerance			
Over/Under Frequency	Trip / Reset			
Phase Sequence				
Response Time-Phase Reversal & Phase Loss				
Reset				
<b>Output</b>		Isolated Electromechanical Relay Double pole double throw (DPDT) 10 A resistive at 240 V AC; 8 A resistive at 277 V AC; N.O.-1/4 hp at 120 V AC; 1/3 hp at 240 V AC; Mechanical -- 1 x 10 <sup>6</sup> Electrical -- (at 10 A) -- DPDT = 1 x 30 <sup>3</sup>		
Type				
Form				
Rating				
Life				
<b>Protection</b>		IEEE C62.41-1991 Level B Isolation Voltage ≥ 2500 V RMS input to output Circuitry Encapsulated		
Surge				
Isolation Voltage				
<b>Mechanical</b>		Surface mount with one #10 (M5 x 0.7) screw Note: 0.25 in.(6.35 mm) spacing between units or other devices is required 3 x 2 x 1.5 in. (76.7 x 51.3 x 41.7 mm) Screw terminal connection for up to 12 AWG (3.3 mm <sup>2</sup> ) wire		
Mounting				
Package				
Termination				
<b>Environmental</b>		-40°C ... +60°C -40°C ... +85°C 95% relative, non-condensing ≅ 3.9 oz (111 g)		
Operating Temperature				
Storage Temperature				
Humidity				
Weight				

7

### Mechanical View

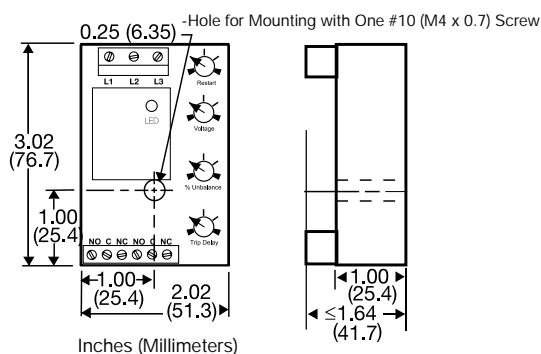

Ambient Temp {Deg. C}

HLMU output rating

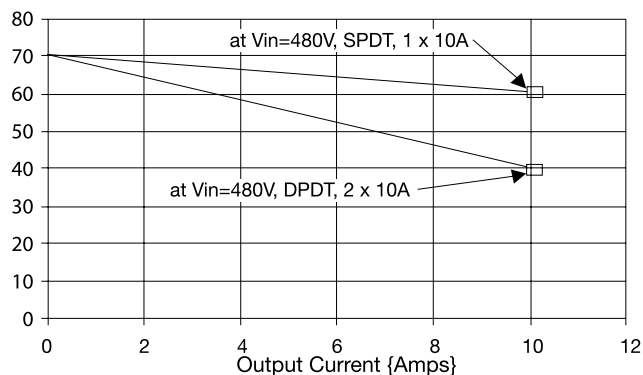

HLM02B01 11.21.06