

AC Current Sensor, PLC Interface Module

TCS Series

Current Sensor

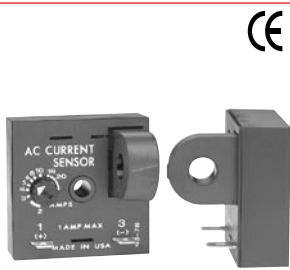

- Direct Connection to a PLC Digital Input Module
- 3 ... 50 V DC, 24 ... 240 V AC in 2 Ranges
- 1 A Steady - 10 A Inrush
- Actuation Points –
2 ... 45 A (Fixed Units)
2 ... 20 A (Adjustable Units)
- Normally Open or Closed Solid State Output
- Complete Isolation Between Sensed Current & Control Circuit

Approvals:

8

Accessories

Female quick connect
P/N: **P1015-64** (AWG 14/16)

Quick connect to screw adaptor
P/N: **P1015-18**

Mounting bracket
P/N: **P1023-6**

DIN rail P/Ns:
017322005 (Steel)
C103PM (Al)
DIN rail adaptor
P/N: **P1023-20**

See accessory pages for specifications.

Description

The TCS Series is a low cost method of GO/NO GO current detection. It includes a solid state output to sink or source current when connected directly to a standard PLC digital input module. Its normally open or normally closed output can also be used to control relays, lamps, valves, and small heaters rated up to 1 A steady, 10 A inrush. The TCS is self-powered (no external power required to operate the unit) available with an adjustable actuation range of 2 to 20 A or factory fixed actuation points from 2 to 45 A.

Operation

Normally Open: When a current equal to or greater than the actuate current is passed through the toroidal sensor, the output closes. When the current is reduced to 95% of the actuate current or less, the output opens.

Normally Closed: When the current through the toroid is equal to or greater than the actuate current, the output opens. When the current is reduced below 95% of the actuate current, the output closes.

Function

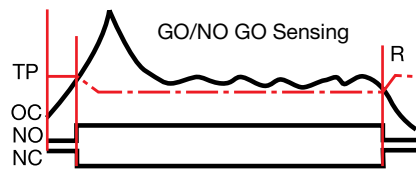

L = Load V = Voltage PS = Power Supply
PLC = PLC Digital Input Module R = Reset
TP = Trip Point OC = Monitored Current
NO = Normally Open Output
NC = Normally Closed Output

Connection

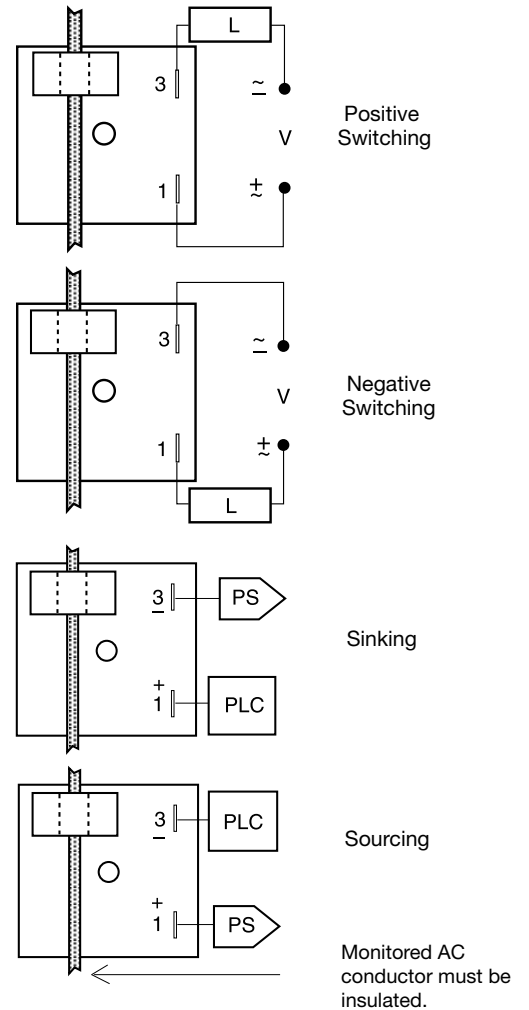

Ordering Table

TCS Series	X Output Voltage	X Actuate Current	X Output Form
	-G - 3 ... 50 V DC	-A - Adjustable 2 ... 20 A	-A - Normally Open
	-H - 24 ... 240 V AC	-Specify Fixed - Actuate Point 2 ... 45 A in 1 A increments	-B - Normally Closed

Example P/N: **TCSGAA** Fixed – **TCSH20A**

AC Current Sensor, PLC Interface Module

TCS Series

Current Sensor

Current
Sensors &
Monitors

Technical Data

Sensor Type Current to Actuate Reset Current Maximum Allowable Current Actuate Current vs. Temperature & Voltage Response Times Burden	Toroid, through hole wiring, alternating current, monitored wire must be properly insulated Adjustable Units -- 2 ... 20 A, Guaranteed Range Fixed Units -- 2 ... 45 A, +0/-20% $\cong 95\%$ of the actuate current Steady -- 50 A-turns Inrush -- 300 A-turns for 10 s $\leq +/ -5\%$ Overcurrent -- ≤ 200 ms Undercurrent -- ≤ 1 s < 0.5 VA
Output Type Form Rating Voltage Voltage Drop	Solid State Normally Open or Normally Closed 1 A steady, 10 A inrush AC -- 24 ... 240 V AC +10/-20% DC -- 3 ... 50 V DC AC N.O. & N.C. -- $\cong 2.5$ V DC N.O. & N.C. -- $\cong 1.2$ V
Protection Circuitry Dielectric Breakdown Insulation Resistance	Encapsulated ≥ 2000 V RMS terminals to mounting surface ≥ 100 M Ω
Mechanical Mounting Package Termination Sensor Hole	Surface mount with one #10 (M5 x 0.8) screw 2 x 2 x 1.75 in. (50.8 x 50.8 x 44.5 mm) 0.25 in. (6.35 mm) male quick connect terminals (2) 0.36 in. (9.14 mm) for up to #4 AWG (21.1 mm ²) THHN wire
Environmental Operating/Storage Temperature Humidity Weight	-20°C ... +60°C / -40°C ... +85°C 95% relative, non-condensing $\cong 2.6$ oz (74 g)

8

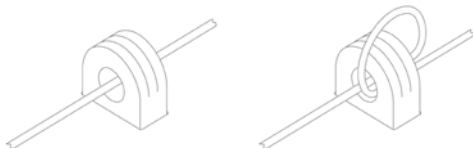

Multiple Turns To Increase Sensitivity

To increase sensitivity, multiple turns may be made through the TCS's toroidal sensor. The trip point range is divided by the number of turns through the toroidal sensor to create a new range.

Using an External Current Transformer (CT)

Select a 2 VA, 0 to 20 A output CT, rated for the current to be monitored. Pass one of the CT's secondary wire leads through the TCS's toroid. Connect the CT's secondary leads together.

Mechanical View

