

Solid State Overload & Monitor ESTM Series Motor Protectors



- Protection of a Line Monitor & Overload in One Package
- Protects Against: Overload, Phase Loss, Current Unbalance, Phase Reversal and Short Cycling
- Meets NEC Code for Motor Overloads
- 1.25 ... 80 A in 3 Adjustable Ranges
- Fast 2.5 s Trip On Phase Loss, Hot or Cold Motor

Description

The ESTM Series protects against premature motor winding failure caused by electrical overheating. It provides the protection of a voltage monitor and an overload in one package. Microcomputer based circuitry calculates overload trip times while compensating for hot/cold motors and additional heat from phase unbalance. Unique patented design requires only two small sensors to measure current in all three phases. The ESTM can be used with any brand of contactor. It provides protection for one motor against phase loss, unbalance, phase reversal, and rapid cycling. Other features are a fast trip delay on phase loss, switch selectable manual reset or automatic restart with delay; remote reset by removing input voltage, and a random start delay after a power outage (auto restart only). Connecting a DC voltmeter to the meter terminals allows for accurate setting of the full load current over a wide 4:1 range. Because of its solid state design, the overcurrent trip point is not affected by ambient temperature.

US Patent #6040689

■ Approvals:

Wires must be properly insulated *

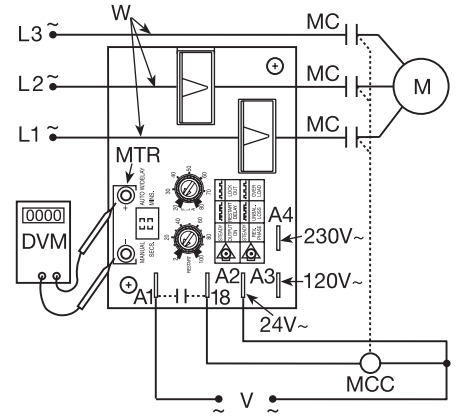

W = Wire V = Voltage MC = Motor Contactor
M = Motor MTR = Meter DVM = Digital Voltmeter
MCC = Motor Contactor Coil

Voltage	FLA Range	Trip Curve	Part Number
24, 120, 230 V AC	1.25 ... 5 A	NEMA Class 20	ESTMA5N20
24, 120, 230 V AC	5 ... 20 A	NEMA Class 20	ESTMA20N20
24, 120, 230 V AC	20 ... 80 A	NEMA Class 20	ESTMA80N20

* 50 to 80 A use 4 AWG 90°C THHN wire.

Short Circuit Rating 80 A Unit - 10KA @ 600 V
5 & 20 A Units - 5KA @ 600 V

Caution: Line Voltage On All Connections & Meter Terminals

A2, A3, A4:
Select The Correct Terminal For The Input Voltage Used

Note: Phase reversal, phase loss are not sensed until the motor is energized & conditions of Phase Reversal, Phase Loss/Unbalance specifications are met.

Technical Data

Motor Protection	
Overload Type	Solid state current sensing; meets NEMA class 20 trip curve
Overload Range	1.25 ... 80 A in 3 adjustable ranges, 60 Hz, +/-1%
Phase Reversal	Trips in ≤ 1 s with motor load ≥ 50% unbalance & motor loaded to ≥ 70%
Phase Loss/Unbalance	Trips in 2.5 s +/-30% with ≥ 50% of minimum FLA setting & current unbalance ≤ 40%
Reset (Restart)	
Type	Manual reset & automatic restart with a delay
Automatic Restart with Delay: Mode	Restart delay begins when a fault trips the unit or when input voltage is applied
Delay Adjustment Ranges	Knob with reference dial Switch selectable on the unit 2 ... 100 s +/-10% or +/-0.5 s, whichever is greater 2 ... 100 m +/-10% or +/-0.5 m, whichever is greater
Auto-Trip Counter	If unit trips 3 times consecutively, unit will lockout until manually reset
Input	
Voltage	24, 120, & 230 V AC, +/-20%, 60 Hz
Power Consumption	0.5 VA @ 24 V AC; 1.2 VA @ 120 V AC; 2.2 VA @ 230 V AC
Output	
Type	Solid state
Form	Single Pole-closed during normal operation
Rating	Input 24 V AC 1.5 @ 40°C, 1.0 A @ 60°C 120 V AC 1.0 @ 50°C, 0.6 A @ 60°C 230 V AC 0.5 @ 50°C, 0.2 A @ 60°C Max. Output A
Inrush	10 A
Voltage Drop	≤ 1.25 V
Leakage Current	0.7 mA @ 24 V AC; 3 mA @ 120 V AC; 6 mA @ 230 V AC
Protection	Surge IEEE C62.41-1991 Level A
Dielectric	≥ 2000 V RMS terminals to mounting surface
Short Circuit Rating	80 A Unit - 10 KA @ 600 V; 5, 20 A Units - 5 KA @ 600 V
Mechanical	
Mounting	Surface mount with two #6 (M 3.5 x 0.6) screws
Connection Terminals	0.25 in (6.35 mm) male quick connect terminals
Wire Selection	50 ... 80 A use #4 AWG (21.1 mm ²) 90°C THHN wire
Environmental	
Operating/Storage Temperature	-40°C ... +60°C / -40°C ... +85°C
Humidity	95% relative, non-condensing
Weight	6.7 oz (190 g)

ESTM...N20 Trip Curves (Balanced Currents)

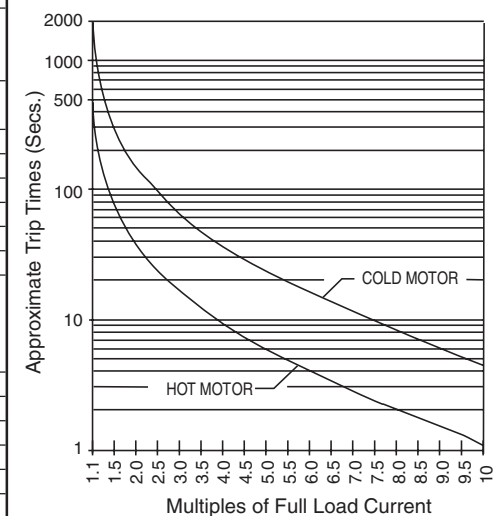

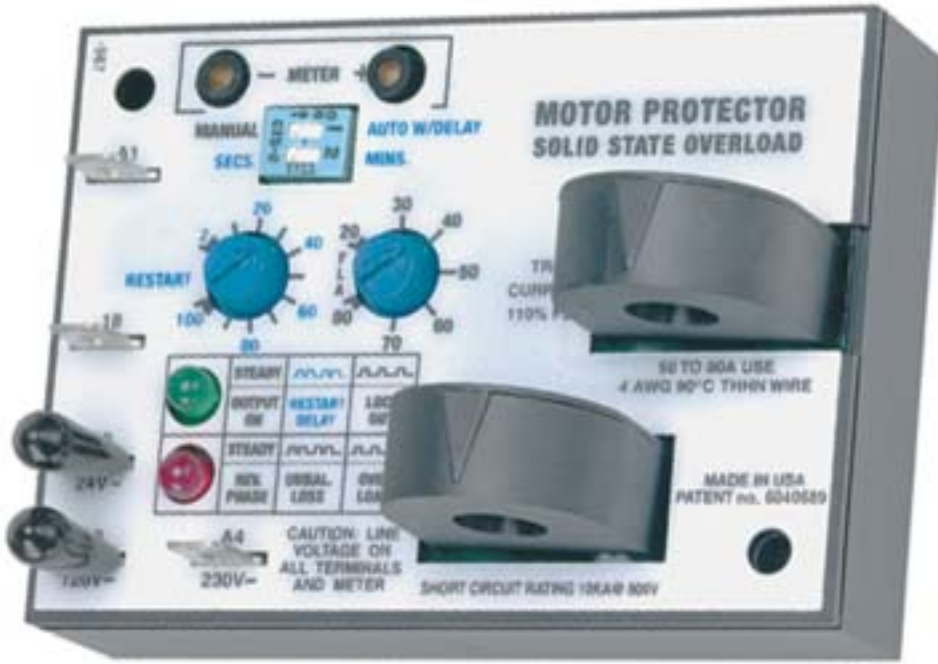

Solid State Overload & Monitor ESTM Series Motor Protectors

Operation

When input voltage is applied, the output energizes either immediately, or after a delay and the green LED glows as long as three phase currents and sequence are acceptable. Upon fault detection, red LED glows, and trip delay begins. Trip delay for overload is determined by trip curve of unit. Trip delays for phase loss and phase reversal are fixed. If the fault is corrected during trip delay, the delay resets. At the end of the trip delay, the output de-energizes. Reset mode is determined by the reset switch setting. A phase reversal fault must be manually reset.

Automatic Restart Mode: Upon application of input voltage, restart delay begins. The output is de-energized during restart delay, and energizes when it ends. Faults (except phase reversal) are displayed until the unit trips. A new restart delay begins as soon as the unit trips. Transferring the reset switch to the manual position during the restart delay energizes output.

Auto-Trip Counter: Three consecutive trips and unit will lockout until manually reset. The green indicator flashes during lockout. The auto-trip counter is reset when the unit operates for five minutes without detecting a fault.

Manual Reset Mode: Upon application of input voltage, the output energizes. When a fault trips the unit, the output must be manually reset. Faults are displayed until reset. Removing input voltage resets unit.

Indicators

Green LED:

- OFF** - Output de-energized
- ON Steady** - Output energized
- Single Flash** - Lockout after 3 consecutive trips, output is de-energized
- Double Flash** - Restart delay, output is de-energized

Red LED:

- OFF** - Average current is acceptable
- ON Steady** - Phase reversal
- Single Flash** - Overload
- Double Flash** - Current unbalance or phase loss

Overload Adjustment:

The FLA adjustment is knob adjustable over a wide 4:1 range. Select the FLA rating shown on the motor name plate. Connecting a digital DC voltmeter to meter terminals provides an accurate means of setting the FLA.

Note: A voltmeter with an input impedance of = 5 M. is recommended.

DC Voltage vs. FLA Setting			
Meter Volts	FLA Set Point (Amps)		
	1.25 - 5	5 - 20	20 - 80
0	1.25	5	20
0.5	1.63	6.50	26.00
1.0	2	8	32
1.5	2.38	9.5	38
2.0	2.75	11	44
2.5	3.13	12.5	50
3.0	3.5	14	56
3.5	3.86	15.5	62
4.0	4.25	17	68
4.5	4.62	18.5	74
5.0	5	20	80

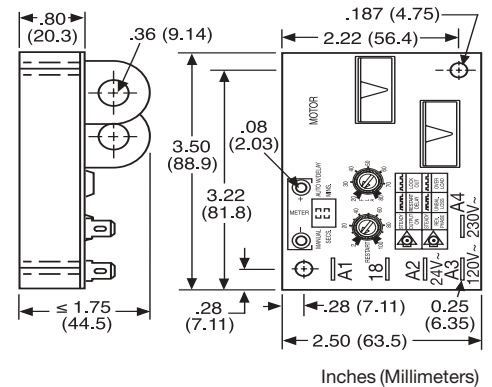

Accessories

- Female quick connect P/Ns:
- P101513** (AWG 10/12)
- P101564** (AWG 14/16)
- P101514** (AWG 18/22)



See accessory page at the end of this section.