

Operation

The output relay is energized when all conditions are acceptable and the WVM is reset. A restart and/or random start delay may occur before the output relay is energized.

Field Adjustment: Select the line voltage listed on the motor's name plate. This automatically sets the over and under voltage trip points. Consult the equipment's manufacturer specifications for the correct trip delay, unbalance percentage, and restart/reset operation and restart delay. Make connection to all three line phases as shown in the connection diagram. Apply power. If the relay fails to energize, view the LEDs for the cause, and correct the problem. If the phase sequence is incorrect, swap any two wires. No further adjustment should be required to achieve maximum equipment protection.

Read Memory: Fault(s) stored in the memory are indicated when the yellow LED is flashing. To read memory, rotate selector from Manual to Read Memory. The last fault will be displayed. Repeat this operation to read the second to the last fault. Repeat until up to 10 faults are noted.

Memory Reset: To clear the memory of all faults stored, rotate selector to Clear Memory for 5 seconds. The yellow LED will turn off.

Memory Overload: The 11th fault causes the first to be removed from memory. Only the 10 most recent faults are retained.

Random Start Delay: A new 3 to 15 s random start delay is selected by the microcontroller when a fault is corrected and when the operating voltage (L1, L2, L3) is applied to the WVM. A random start delay does not occur when the reset is manual.

Automatic Restart: Upon fault correction, the output will re-energize after a random start delay.

Automatic Restart Upon Fault Trip: When a fault is sensed for the full trip delay, the output de-

energizes and a restart delay is initiated. This delay locks out the output for the delay period. Should the fault be corrected by the end of the restart delay, the output will re-energize after a random start delay. A restart delay will also occur when operating voltage (L1, L2, L3) is applied to the WVM.

Manual Reset: After a fault condition is corrected, the WVM can be manually reset. There are two methods; a switch on the unit or a customer supplied remote switch.

Manual Reset Units: (P/N ends with **M**) These part numbers have a 3 position selector switch. An on board momentary reset switch is provided on the unit for manual reset.

Switch Selected Reset Units: (P/N includes an **A** or **R**) These part numbers have a 5 position selector switch. Rotate selector switch from the Manual Reset position to Auto Restart w/ Delay then back again to Manual Reset within 3 seconds. The output will immediately energize.

Remote Reset: Reset (Restart) is accomplished by a momentary contact closure across terminals 1 & 2. The output will immediately energize. Remote switch requirements are ≥ 10 mA at 20 V DC and the reset terminals are not isolated from line voltage. A resistance of $\leq 20K\Omega$ across terminals 1 & 2 will cause immediate automatic restart.

Automatic Restart Upon Fault Correction: (P/N includes an **R**)
When a fault is sensed for the full trip delay, the output relay de-energizes. Upon correction of the fault, a restart delay begins. At the end of this delay, the output will re-energize after a random start delay. If a fault occurs during timing, the restart delay will be reset to zero, and the output will not energize until the restart delay is completed.

**3 Phase Voltage Monitor
WVM Series
Motor Protector**

Accessories

Clear Tamperproof Cover

The P0500-153 protects against unauthorized adjustment of the trip points. It prevents the resetting of manual units by the equipment's operator. It isolates line-level connection points preventing contact during troubleshooting operations. Alignment dimples allow drilling (5 places) for limited access to adjustment knobs and the reset switch. Included are (2) spacers, (5) hole plugs. 7.5 x 4.7 x 2.6 in. (190.5 x 119.4 x 66 mm)

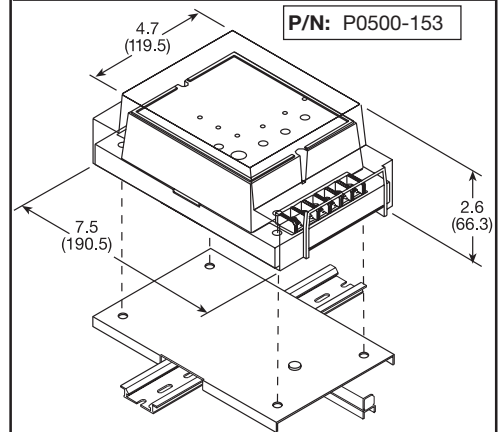

Inches (Millimeters)

P/N: P1011-38

35mm DIN Rail Adaptor

The P1011-38 provides an easy method of mounting the WVM Series on 35mm DIN rail. Constructed of rugged black anodized steel, the P1011-38 adaptor includes four mounting screws. 7 x 4.5 x .33 in. (177.8 x 114.3 x 8.4 mm)

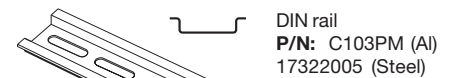

Midget Fuse

Fast acting fuse for use with voltage monitors. Rated 2 A at 500 V AC. 1.5 x 0.41 in. (38.1 x 10.3 mm)
P/N: P0600-11

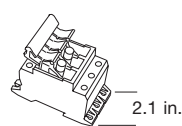

Three phase fuse block disconnect designed for use with HRC midget fuses [1.5 x 0.41 in.] (38.1 x 10.3 mm) rated up to 25 A at 500 V AC. Surface or 35mm DIN rail mountable. 3.9 x 2.09 x 2.2 in. (99 x 53.1 x 55.9 mm)
P/N: P0700-241