

Recycling (Flasher) THD3 Digi-Power Power Timing Module

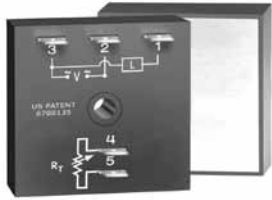

5

- High Load Currents up to 20 A, 200 A Inrush
- Fixed or Adjustable Delays From 0.1 s ... 1000 m
- +/-0.5% Repeat Accuracy
- +/-1% Factory Calibration
- 24, 120, or 230 V AC
- Metallized Mounting Surface for Efficient Heat Transfer
- Totally Solid State and Encapsulated

Approvals:

Accessories

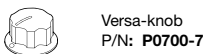
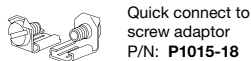
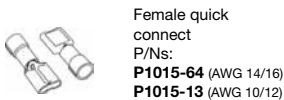
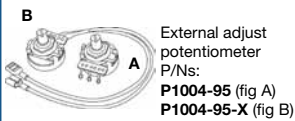

See accessory pages for specifications.

Description

The THD Series combines accurate timing circuitry with high power solid state switching. It can switch motors, lamps, and heaters directly without a contactor. The THD3 has equal ON and OFF time delays. A single RT sets both time delays. You can reduce labor, component cost, and increase reliability with these small, easy-to-use, Digi-Power timers.

Operation (ON Time First)

Upon application of input voltage, the output energizes and the T1 ON time begins. At the end of the ON time, the output de-energizes and the T2 OFF time begins. At the end of the OFF time, the output energizes and the cycle repeats as long as input voltage is applied.

Reset: Removing input voltage resets the output and time delays, and returns the sequence to T1, ON time.

Operation (OFF Time First)

Upon application of input voltage, the T2, OFF time begins. At the end of the OFF time, the T1, ON time begins and the load energizes. At the end of T1, T2 begins and the load de-energizes. This cycle repeats until input voltage is removed.

Reset: Removing input voltage resets the output and the sequence to T2, OFF time.

Function

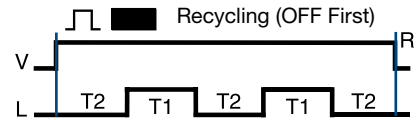
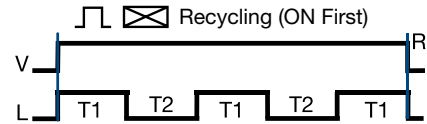

V = Voltage R = Reset L = Load
T1 = ON Time T2 = OFF Time
T1 ≅ T2

Connection

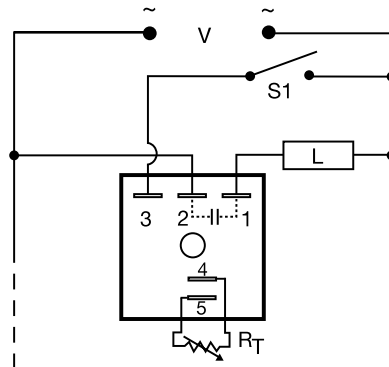

RT is used when external adjustment is ordered.
Dashed lines are internal connections.
S1 = Optional Low Current Initiate Switch

Available Models-

THD3A41A0.5S

THD3C42A0

THD3C43A0

Don't see what you need? Call us for a minimum quantity and price quote!

Ordering Table

THD3 Series	X Output Rating	X Input	X Adjustment	X Operating Sequence	X Time Delay *
-A	6 A	-2 - 24 V AC	-1 - Fixed	-A - ON Time First	-0 - 0.1 ... 10 s
-B	10 A	-4 - 120 V AC	-2 - External Adjust	-B - OFF Time First	-1 - 1.0 ... 100 s
-C	20 A	-6 - 230 V AC	-3 - Onboard Adjust		-2 - 10 ... 1000 s
					-3 - 0.1 ... 10 m
					-4 - 1 ... 100 m
					-5 - 10 ... 1000 m

Example P/N: **THD3B42A0**
Fixed - **THD3A41A0.1S**

*If Fixed Delay is selected, insert delay [0.1...1000] followed by (S) secs. or (M) mins.

Recycling (Flasher) THD3 Digi-Power Power Timing Module

Dedicated
timers

Technical Data

Time Delay		0.1 s ... 1000 m in 6 adjustable ranges or fixed		
Range		Single variable resistor changes both the		
Adjustment		ON & OFF times equally		
Repeat Accuracy		+/-0.5% or 20 ms, whichever is greater		
Tolerance (Factory Calibration)		≤ +/-1%		
Reset Time		≤ 150 ms		
Time Delay vs. Temperature & Voltage		≤ +/-2%		
Input				
Voltage		24, 120, or 230 V AC		
Tolerance		+/-20%		
Line Frequency		50 ... 60 Hz		
Power Consumption		≤ 2 VA		
Output				
Type		Solid state		
Maximum Load Current		Output	Steady State	Inrush**
		A	6 A	60 A
		B	10 A	100 A
		C	20 A	200 A
Minimum Load Current		100 mA		
Voltage Drop		≅ 2.5 V at rated current		
OFF State Leakage Current		≅ 5 mA at 230 V AC		
Protection				
Circuitry		Encapsulated		
Dielectric Breakdown		≥ 2000 V RMS terminals to mounting surface		
Insulation Resistance		≥ 100 MΩ		
Mechanical				
Mounting **		Surface mount with one #10 (M5 x 0.8) screw		
Termination		0.25 in. (6.35 mm) male quick connect terminals		
Environmental				
Operating/ Storage Temperature		-40°C ... +60°C / -40°C ... +85°C		
Humidity		95% relative, non-condensing		
Weight		≅ 3.9 oz (111 g)		

5

**Must be bolted to a metal surface using the included heat sink compound. The maximum mounting surface temperature is 90°C. Inrush: Non-repetitive for 16 ms.

External Resistance vs Time Delay

In Secs. or Mins.

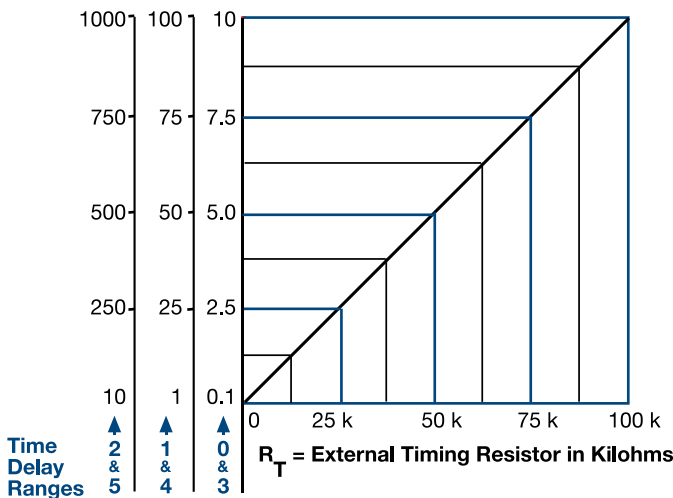

This chart applies to externally adjustable part numbers.
The time delay is adjustable over the time delay range selected by varying the resistance across the R_T terminals; as the resistance increases the time delay increases.
When selecting an external R_T , add the tolerances of the timer and the R_T for the full time range adjustment.
Examples: 1 to 50 S adjustable time delay, select time delay range 1 and a 50 K ohm R_T . For 1 to 100 S use a 100 K ohm R_T .

Mechanical View

Fixed & External Adjust

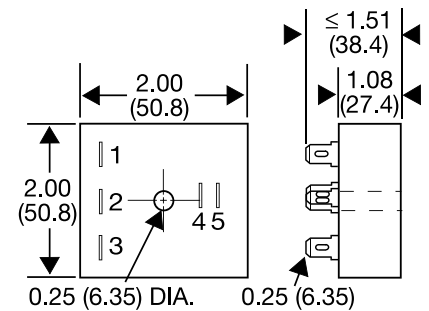

Onboard Adjust

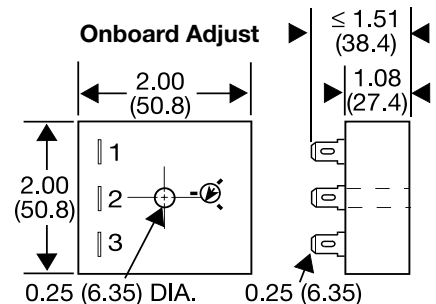

Inches (Millimeters)

THD3Gen 09.10