

# KSPU Series Timing Module



US Patent 6708135



- Choose 1 of 14 Standard Functions
- Special Time Ranges and Functions Available
- Factory Programmed
- Microcontroller Circuitry, +/-0.1% Repeat Accuracy
- Solid State Output 1 A Steady, 10 A Inrush
- Accurate Switch Adjustment
- 12 ... 240 V in 3 Ranges
- Delays from 100 ms...1023 h in 6 ranges
- Counts to 1023 in 3 Ranges

Approvals:

## Description

The KSPU Series is a factory programmed module available in any 1 of 14 standard functions. The KSPU offers a single adjustable timer or counter function. Modules are manufactured without the function assigned. When an order is received, the function software is added. This approach provides fast delivery on all part numbers. Switch adjustment allows accurate selection of the time delay or number of counts the first time and every time. The 1 A steady, 10 A inrush rated solid state output provides 100 million operations, typical. Its microcontroller timing circuit provides excellent repeat accuracy and stability. Encapsulation protects against shock, vibration, and humidity. The KSPU Series is a cost effective approach for OEM applications that require small size, solid state reliability, and accurate switch adjustment. Special time ranges and functions are available; contact Technical Assistance (see below) for more information.

## Connection

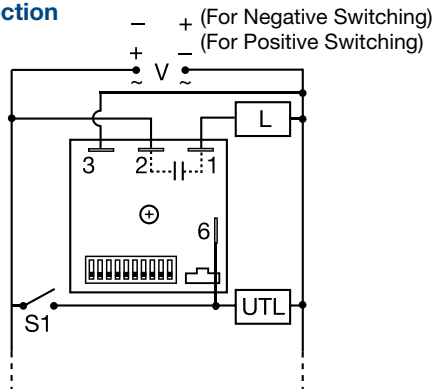

V = Voltage S1 = Initiate Switch  
L = Load UTL = Untimed Load

The untimed load is optional. S1 is not used for some functions. Dashed lines are internal connections.

## Switch Adjustment

Adjustment Switch Operation			
TIME DELAY		COUNTER	
0.1...102.3	1...1023	1...165	1...63
OFF ▶ ON	OFF ▶ ON	OFF ▶ ON	OFF ▶ ON
6.3	544	57 counts	44 s Delay 2 counts to Start

One or more switches must be ON for proper operation.

## Available Models-

KSPU11M	KSPU42I	KSPU92I
KSPUA2I	KSPUA8C	KSPUP1M
KSPUP3B		

Don't see what you need? Call us for a minimum quantity and price quote!

## Ordering Table

KSPU Series	X Input	X Time Delay/Counts	X Function**
	A - 24 ... 240 V AC	-1 - 0.1 ... 102.3 s	- Specify Function (Refer to Function Chart for Code)
	P - 12 ... 120 V DC Positive Switching	-2 - 1 ... 1023 s	
	N - 12 ... 120 V DC Negative Switching	-3 - 0.1 ... 102.3 m	
		-4 - 1 ... 1023 m	
		-5 - 0.1 ... 102.3 h	
		-6 - 1 ... 1023 h	
		-7 - 1 ... 165 counts (straight) w/pulsed output	
		-8 - 1 ... 1023 counts (binary) w/pulsed output	
		-9 - 1 ... 7 counts to start 1 ... 63 s or m interval time	

Example P/N: **KSPUA2RE**

## Mechanical View

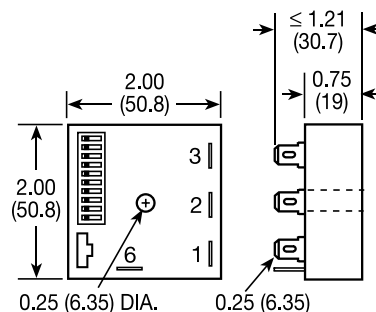

Inches (Millimeters)

## \*\*Function Chart

- Delay on Make
- Delay on Break
- Recycle (ON Time First, Equal Times)
- Recycle (OFF Time First, Equal Times)
- Single Shot
- Interval
- Trailing Edge Single Shot
- Inverted Single Shot
- Inverted Delay on Break
- Accumulative Delay on Make
- Motion Detector/Retriggerable
- Single Shot
- Counter/Pulsed Output
- Counter/Interval Output

## Code

- M
- B
- RE
- RD
- S, SD
- I
- TS
- US
- UB
- AM
- PSD
- C
- CI

For a Complete List of Functions with Descriptions, see Timer Function Section.

## Accessories

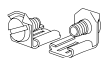

Quick connect to screw adaptor  
P/N: **P1015-18**



Female quick connect P/Ns:  
**P1015-64** (AWG 14/16)  
**P1015-14** (AWG 18/22)

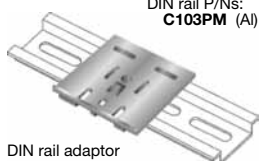

DIN rail P/Ns:  
**C103PM** (Al)

DIN rail adaptor  
P/N: **P1023-20**

See accessory pages for specifications.

# KSPU Series Timing Module

## Technical Data

<b>Time Delay</b> Type Range  Repeat Accuracy Setting Accuracy Reset Time Initiate Time Time Delay / Temp. & Voltage Count Range Count Rate	Microcontroller circuitry 0.1 ... 102.3 s, m or h in 0.1 s, m or h increments 1 ... 1023 s, m or h in 1 s, m or h increments 1 ... 63 s or m in 1 s or m increments +/-0.1% or 20 ms, whichever is greater ≤ +/-1% or 20 ms, whichever is greater ≤ 150 ms ≤ 20 ms ≤ +/-2% 1 ... 1023 in 3 ranges ≤ 25 counts per second	<b>Protection</b> Circuitry Dielectric Breakdown Insulation Resistance Polarity	Encapsulated ≥ 2000 V RMS terminals to mounting surface ≥ 100 MΩ DC units are reverse polarity protected
<b>Input</b> Voltage Tolerance Frequency/DC Ripple Power Consumption	12 ... 120 V DC; 24 ... 240 V AC ≤ +/-15% 50 ... 60 Hz / ≤ 10% AC ≤ 2 VA; DC ≤ 1 W	<b>Mechanical</b> Mounting Package Termination	Surface mt. with one #10 (M5 x 0.8) screw 2 x 2 x 1.21 in. (50.8 x 50.8 x 30.7 mm) 0.25 in. (6.35 mm) male quick connects
<b>Output</b> Type Rating Voltage Drop OFF State Leakage Current Counter Output (P/N Variable 7 & 8)	Solid state output 1 A steady, 10 A inrush for 16 ms AC ≅ 2.5 V at 1 A; DC ≅ 1 V at 1A AC ≅ 5 mA at 240 V AC; DC ≅ 1mA Output Pulse width: 300 ms +/-20%	<b>Environmental</b> Operating Temp. Storage Temp. Humidity Weight	-40°C ... +60°C -40°C ... +85°C 95% relative, non-condensing ≅ 2.4 oz (68 g)

## Function Diagrams

For a Complete List of Functions with Descriptions, see Timer Function Section.

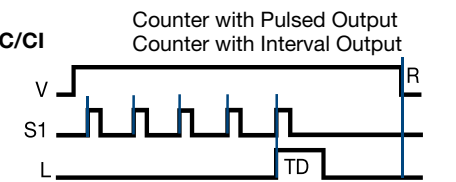
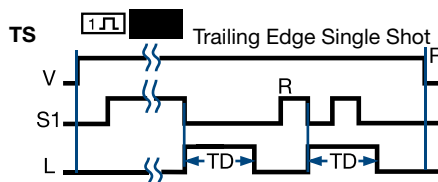
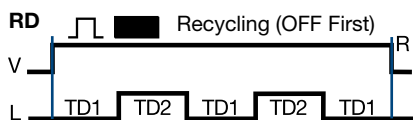
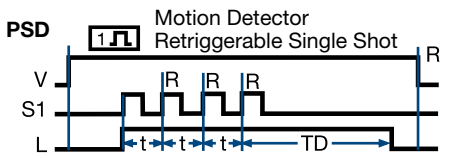
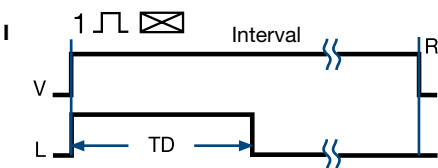
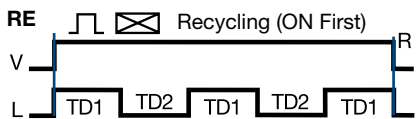
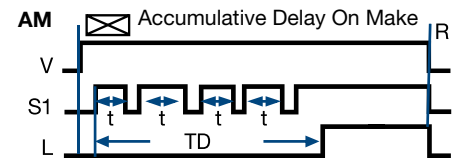
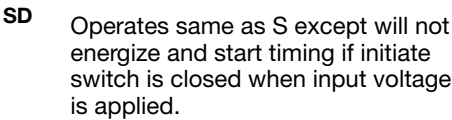
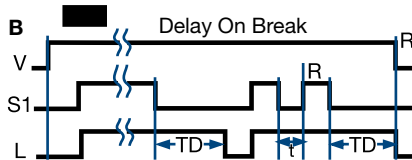
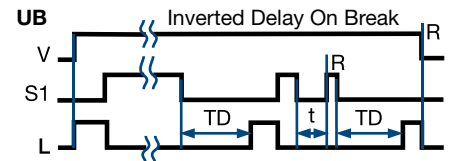
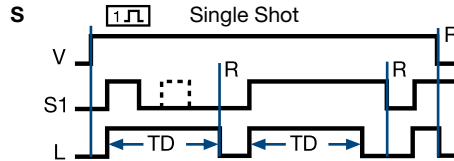
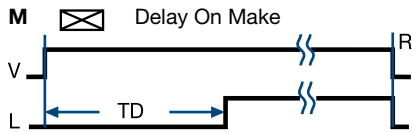

Note: If S1 is closed when input voltage is applied, the function starts and the time delay begins. (B, S, TS, US, UB, AM, PSD, C, C)

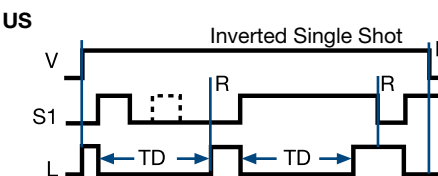

## Legend

V	Voltage
R	Reset
S1	Initiate Switch
L	Output & Load
TD, TD1, TD2	Time Delay
t	Incomplete Time Delay
—  —	Undefined time