

# 3 Phase Voltage Monitor DLM Series Motor Protector



ANSI Device #27/47/59



- Protects Against: Phase Loss, Phase Reversal, Overvoltage, Undervoltage, and Voltage Unbalance
- 35 mm DIN Rail or Surface Mounting
- SPDT Isolated 10 A Relay Contacts
- LED Glows when All Conditions are Acceptable
- Line Voltage 110 ... 600 V AC, in 5 Ranges
- 3 Wire Connection for Delta or Wye Systems
- ASME A17.1 rule 210.6
- NEMA MG1 14:30, 14:35
- IEEE C62.41-1991 Level B

Approvals:    
Listed

## Accessories

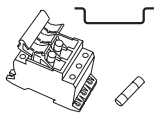

3-phase fuse block/disconnect  
P/N: P0700-241  
2 Amp Fuse  
P/N: P0600-11

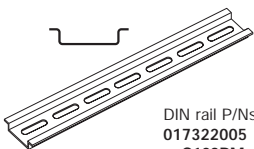

DIN rail P/Ns:  
017322005 (Steel)  
C103PM (Al)

See accessory pages for specifications.

## Description

The DLM Series continuously measures the voltage of each of the three phases. It separately senses under and over voltage, voltage unbalance including phase loss and phase reversal. Protection is assured during periods of large average voltage fluctuations, or when regenerated voltages are present. It can be mounted on 35 mm DIN rail or surface mounted with two screws. All connections are screw terminals with clamps. Connections can be covered with included removeable covers.

## Operation

The output relay is energized and the LED glows when all voltages are acceptable and the phase sequence is correct. Undervoltage, overvoltage, and voltage unbalance must be sensed for continuous trip delay period before the relay and the LED are de-energized. Re-energization is automatic upon correction of the fault condition. The output relay will not energize if a fault condition is sensed as power is applied.

## Field Adjustment:

Set voltage, trip delay, and voltage unbalance percentage (consult equipment manufacturer's specifications). Make connection to all three line phases as shown in the connection diagram. Apply power. If the relay fails to energize, check the wiring of all 3 phases, voltage, and phase sequence. If phase sequence is incorrect, swap any two wires. No further adjustment should be required to achieve maximum equipment protection.

## Connection

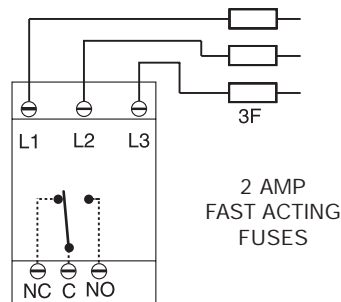

F = Fuses NO = Normally Open

NC = Normally Closed C = Common, Transfer Contact

**CAUTION:** 2 amp max fast acting fuses must be installed externally in series with each input.

## Ordering Table

Voltage	Voltage Unbalance	Trip Delay	Part Number
120 V AC	2 ... 8%	2 ... 20 s	DLM411
240 V AC	2 ... 8%	2 ... 20 s	DLM611
380 V AC	2 ... 8%	2 ... 20 s	DLM811
480 V AC	2 ... 8%	2 ... 20 s	DLM911
600 V AC	2 ... 8%	2 ... 20 s	DLM011

# 3 Phase Voltage Monitor DLM Series Motor Protector

## Technical Data

<b>Line Voltage</b>	3 phase Delta or Wye with no connection to neutral			
Type	<b>Model</b>	<b>Line Voltage Range</b>	<b>Line Voltage Max.</b>	<b>Calibration Frequency</b>
Operating Voltage	120	110 ... 130 V AC	145 V AC	60 Hz
	240	200 ... 240 V AC	270 V AC	60 Hz
	380	360 ... 430 V AC	480 V AC	50 Hz
	480	400 ... 480 V AC	530 V AC	60 Hz
	600	500 ... 600 V AC	600 V AC	60 Hz
Line Frequency	50 ... 60 Hz			
Phase Sequence	ABC			
<b>Overvoltage, Undervoltage &amp; Voltage Unbalance</b>	Voltage detection with delayed trip & automatic reset			<b>Voltage Unbalance</b>
Type				Selected Unbalance %
Overvoltage & Undervoltage:				Reset %
Undervoltage Trip Point	88 ... 92% of adjusted line voltage			2
Reset Voltage	+3% of trip voltage			3
Overvoltage Trip Point	109 ... 113% of adjusted line voltage			4
Reset Voltage	-3% of trip voltage			5
Voltage Unbalance:				6
Trip Unbalance	Adjustable from 2 ... 8%			7
Trip Delay:	Adjustable from 2 ... 20 s			8
Range	Adjustable-Guaranteed range			
Tolerance				
<b>Phase Reversal</b>				
Response Time -- Phase Reversal	≤100 ms			
Reset	Automatic			
<b>Output</b>				
Type	Electromechanical relay			
Form	Single pole double throw (SPDT)			
Rating	10 A resistive @ 240 V AC; 1/4 hp @ 125 V AC; 1/3 hp @ 250 V AC; max. voltage 277 V AC			
Life	Mechanical -- 1 x 10 <sup>6</sup> ; Electrical -- 1 x 10 <sup>5</sup>			
<b>Protection</b>				
Surge	IEEE C62.41-1991 Level B			
Isolation Voltage	≥ 2500 V RMS input to output			
Circuitry	Encapsulated			
<b>Mechanical</b>				
Mounting	Surface with 2 #8 (M4 x 0.7) screws or 35 mm DIN rail			
Package	4.33 x 2.95 x 1.97 in. (110 x 75 x 50 mm)			
Termination	Screw terminals with captive wire clamps for up to #14 AWG (2.5 mm <sup>2</sup> ) wire Touch proof terminal covers are included			
<b>Environmental</b>				
Operating/Storage Temperature	-40°C ... +60°C / -40°C ... +85°C			
Humidity	95% relative, non-condensing			
Weight	120 & 240 V AC	≅ 8.6 oz (244 g)		
	380 ... 600 V AC	≅ 16.3 oz (462 g)		

**Note:** A 60 Hz unit used on 50 Hz will shift by -1. A 50 Hz unit used on 60 Hz will shift by +1. (Ex. 4% unbalance on 60 Hz, would be 3% unbalance on 50 Hz.)

### Mechanical View

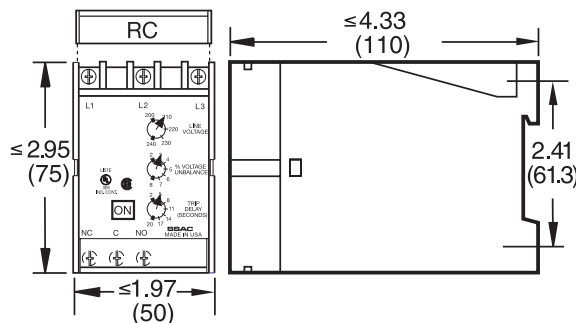

**Mounting Note:**  
Adequate ventilation must be provided. The Ambient Temperature can not exceed 60° C. In some installations at 480 and 600 V AC, there must be up to 0.5 in. (12.2 mm) of space between the DLM and other components.

Inches (Millimeters)  
RC = Removable Terminal Cover