

# HSPZ Series Timing Module



US Patent 6708135



- Choose 1 of 13 Standard Functions
- Special Time Ranges and Functions Available
- Factory Programmed
- Microcontroller Circuitry, +/-0.1% Repeat Accuracy
- 1 A Solid State Output
- Accurate Switch Adjustment
- 12 ... 240 V in 3 Ranges
- Delays from 100 ms...1023 h in 6 ranges
- Counts to 1023 in 2 Ranges

Approvals:

### Accessories



Quick connect to screw adaptor  
P/N: **P1015-18**



Female quick connect  
P/Ns:  
**P1015-64** (AWG 14/16)  
**P1015-14** (AWG 18/22)



DIN rail P/Ns:  
**C103PM** (Al)

See accessory pages for specifications.

### Description

The HSPZ Series is a factory programmed module available in any 1 of 13 standard functions. The HSPZ offers dual switch adjustable timer or counter functions. Modules are manufactured without the function assigned. When an order is received, the function software is added. This approach provides fast delivery on all part numbers. Switch adjustment allows accurate selection of the time delay or number of counts the first time and every time. The 1 A steady, 10 A inrush rated solid state output provides 100 million operations, typical. Its microcontroller timing circuit provides excellent repeat accuracy and stability. Encapsulation protects against shock, vibration, and humidity. The HSPZ Series is a cost effective approach for OEM applications that require small size, solid state reliability, and accurate switch adjustment. Special time ranges and functions are available; contact Technical Assistance (see below) for more information.

### Connection

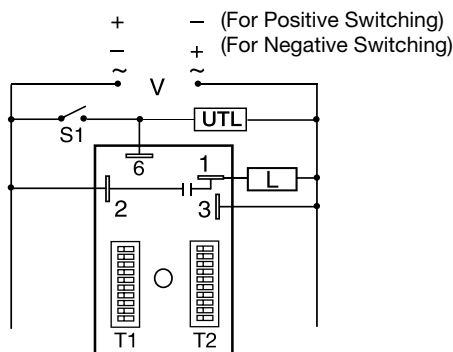

V = Voltage S1 = Initiate Switch  
L = Load UTL = Optional Untimed Load

The untimed load is optional. S1 is not used for some functions. Dashed lines are internal connections.

### Adjustment Switch

Adjustment Switch Operation			
TIME DELAY		TIME DELAY and COUNTER	
0.1...102.3	1...512	1...1023	1...165
OFF ▶ ON	OFF ▶ ON	OFF ▶ ON	OFF ▶ ON
0.1	1	1	1
0.2	2	2	2
0.4	4	4	3
0.8	8	8	4
1.6	16	16	5
3.2	32	32	10
6.4	64	64	20
12.8	128	128	30
25.6	256	256	40
51.2	M	512	50
6.3	300 s Delay	544	57 counts

Add the value of switches in the ON position for the total time delay or count.

### Available Models-

HSPZA22SL

Don't see what you need? Call us for a minimum quantity and price quote!

### Mechanical View

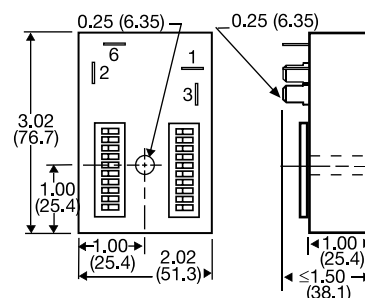

Inches (Millimeters)

### \*\*Function Chart

- Delay On Make/Delay on Break
- Delay On Make/Recycle (ON Time First, Equal Times)
- Delay On Make/Interval
- Delay On Make/Single Shot Interval/Recycle (ON Time First, Equal Times)
- Delay On Break/Recycle (ON Time First, Equal Times)
- Single Shot/Recycle (ON Time First, Equal Times)
- Recycle (Both Times Adjustable, ON Time First)
- Recycle (Both Times Adjustable, OFF Time First)
- Interval/Delay On Make
- Accumulative Delay On Make/Interval
- Single Shot/Lockout
- Counter with Interval Output

### Code

- MB**
- MRE**
- MI**
- MS**
- IRE**
- BRE**
- SRE**
- RXE**
- RXD**
- IM**
- AMI**
- SL**
- CI**

For a Complete List of Functions with Descriptions, see Timer Function Section.

### Ordering Table

HSPZ Series	X
Input	
A - 24 ... 240 V AC	
P - 12 ... 120 V DC Positive Switching	
N - 12 ... 120 V DC Negative Switching	

Example P/N: **HSPZA12MB**

X	T1 Time Delay/Counts
1	0.1 ... 102.3 s
2	1 ... 1023 s
3	0.1 ... 102.3 m
4	1 ... 1023 m
5	0.1 ... 102.3 h
6	1 ... 1023 h
7	1 ... 165 counts (straight)
8	1 ... 1023 counts (binary)
9	1 ... 512 m or s

X	T2 Time Delay/Counts
1	0.1 ... 102.3 s
2	1 ... 1023 s
3	0.1 ... 102.3 m
4	1 ... 1023 m
5	0.1 ... 102.3 h
6	1 ... 1023 h
7	For Future Expansion
8	For Future Expansion
9	1 ... 512 m or s

X  
Function\*\*  
Specify Function (Refer to Function Chart for Code)

# HSPZ Series Timing Module

## Technical Data

<b>Time Delay</b> Type Range  Repeat Accuracy Setting Accuracy Reset Time Initiate Time Time Delay/Temp. & Voltage Count Range Count Rate	Microcontroller circuitry 0.1 ... 102.3 s, m or h in 0.1 s, m or h increments 1 ... 1023 s, m or h in 1 s, m or h increments 1 ... 512 s or m in 1 s or m increments +/-0.1% or 20 ms, whichever is greater ≤ +/-1% or 20 ms, whichever is greater ≤ 150 ms ≤ 20 ms ≤ +/-2% 1 ... 1023 in 2 ranges ≤ 25 counts per second	<b>Protection</b> Circuitry Dielectric Breakdown Insulation Resistance Polarity	Encapsulated ≥ 2000 V RMS terminals to mounting surface ≥ 100 MΩ DC units are reverse polarity protected
<b>Input</b> Voltage Tolerance Frequency/DC Ripple Power Consumption	12 ... 120 V DC; 24 ... 240 V AC ≤ +/-15% 50 ... 60 Hz / ≤ 10% AC ≤ 2 VA; DC ≤ 1 W	<b>Mechanical</b> Mounting Package Termination	Surface mt. with one #10 (M5 x 0.8) screw 2 x 2 x 1.21 in. (50.8 x 50.8 x 30.7 mm) 0.25 in. (6.35 mm) male quick connects
<b>Output</b> Type Rating Voltage Drop OFF State Leakage Current Counter Output (P/N Variable 7 & 8)	Solid state output 1 A steady, 10 A inrush for 16 ms AC ≅ 2.5 V at 1 A; DC ≅ 1 V at 1 A AC ≅ 5 mA at 240 V AC; DC ≅ 1 mA Output Pulse width: 300 ms +/-20%	<b>Environmental</b> Operating Temp. Storage Temp. Humidity Weight	-40°C ... +60°C -40°C ... +85°C 95% relative, non-condensing ≅ 2.4 oz (68 g)

## Function Diagrams

For a Complete List of Functions with Descriptions, see Timer Function Section.

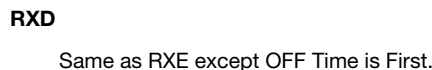
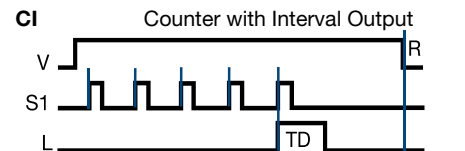
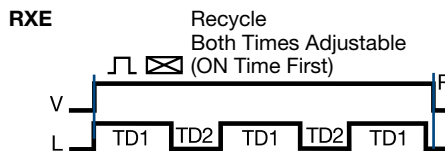
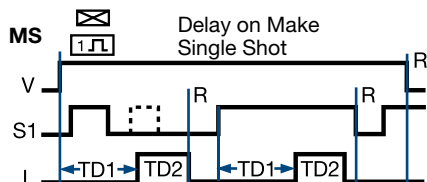
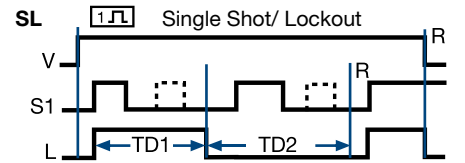
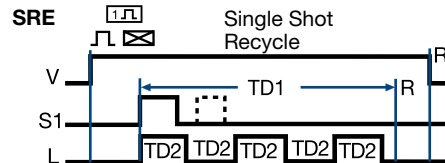
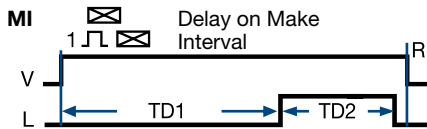
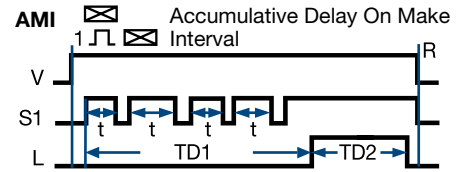
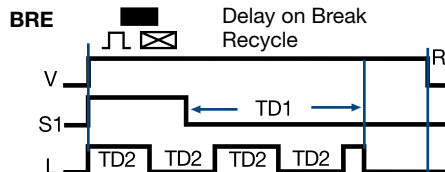
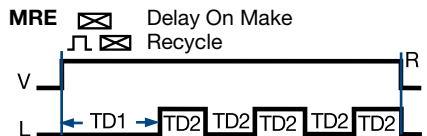
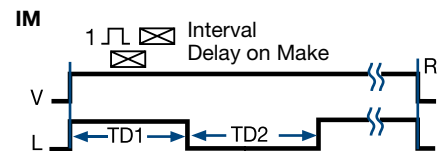
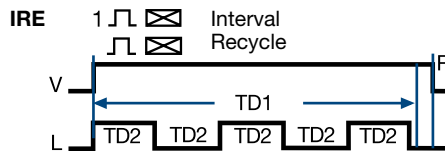
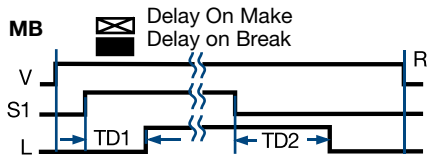

### Legend

V	Voltage
R	Reset
S1	Initiate Switch
L	Output & Load
TD, TD1, TD2	Time Delay
t	Incomplete Time Delay
— —	Undefined time

Note: If S1 is closed when input voltage is applied, the function starts and the time delay begins. (MB, MS, BRE, SRE, AMI, SL, C)